

# BOITE DE VITESSES -calage des arbres

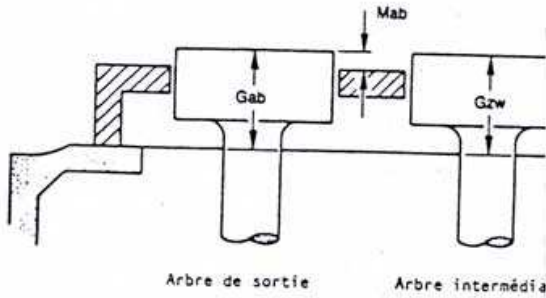
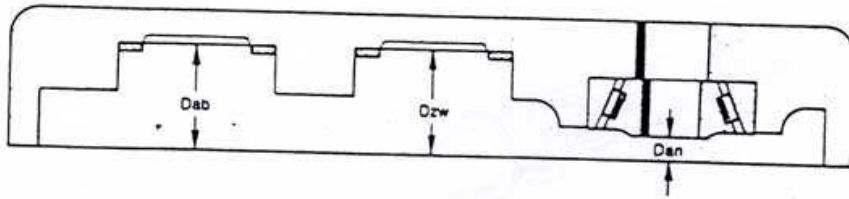

Mzw = 146,12

30,00  
20,50

Mesures (en mm)

Arbre de „ab

11,30

- H Epaisseur de la plaque
- + M Mesuré
- = G
- D Mesuré
- G
- = Jeu sans cales
- Jeu axial
- = Epaisseur des cales

DU BON :

1514,65

-0,05

-0,05

± 0,05

BMW Moto

# arbres d'entrée et intermediaire

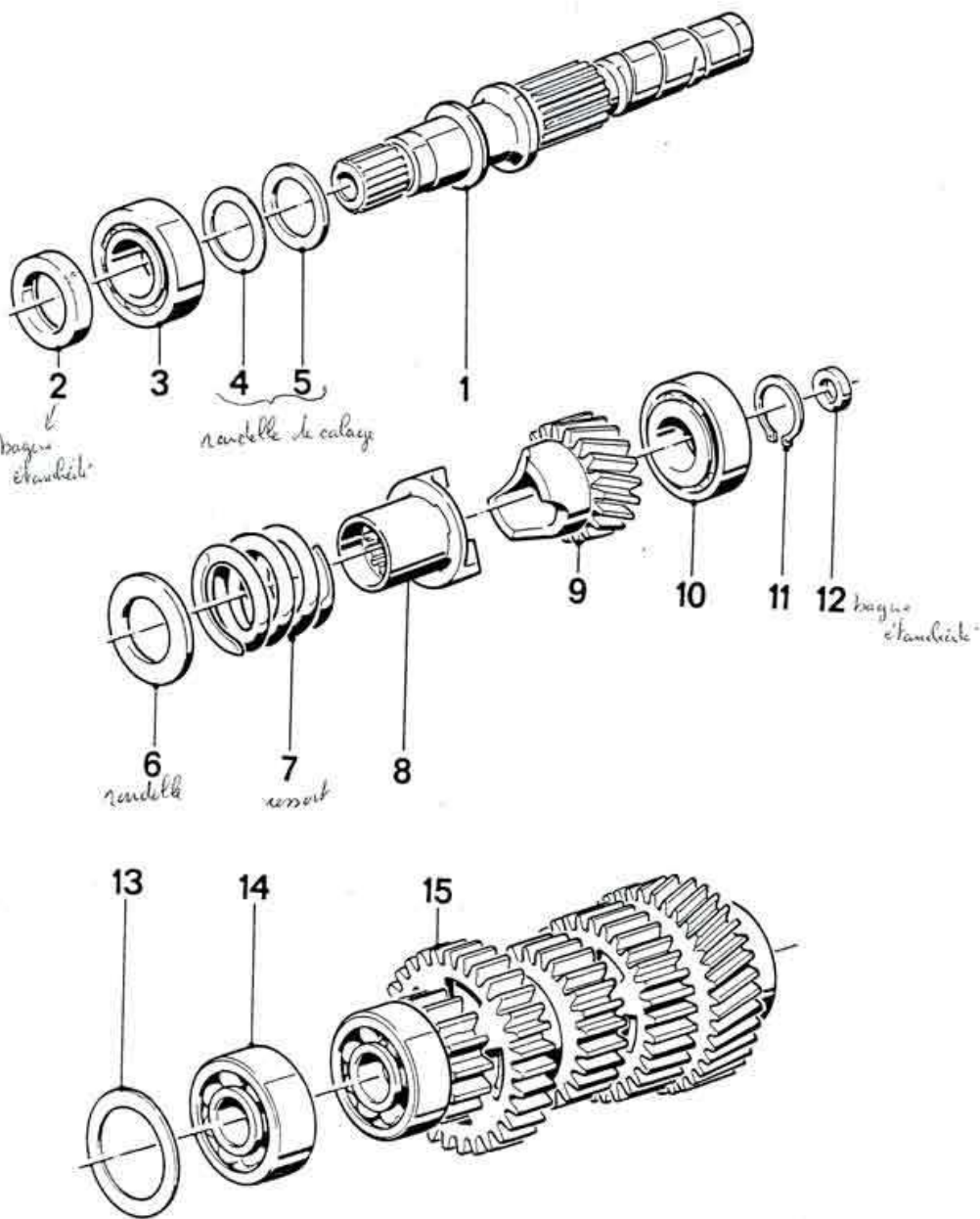

BMW Moto



Correction à apporter à la cote de base du pignon. (k)

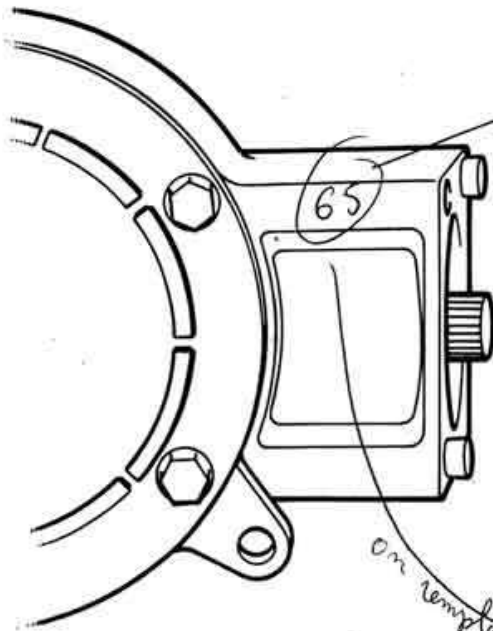
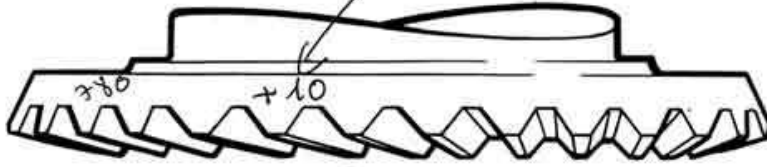

correction à apporter à la cote de base du carter = (G)

$$K = 77,50 + 0,10 = 77,6$$

$$G = 75,65$$

on remplace le 0,50 par

Cote de réglage de distance Cam/carter

$$= K - G = 77,6 - 75,65 = \boxed{1,95}$$

BMW Moto

Précontrainte = 10,05

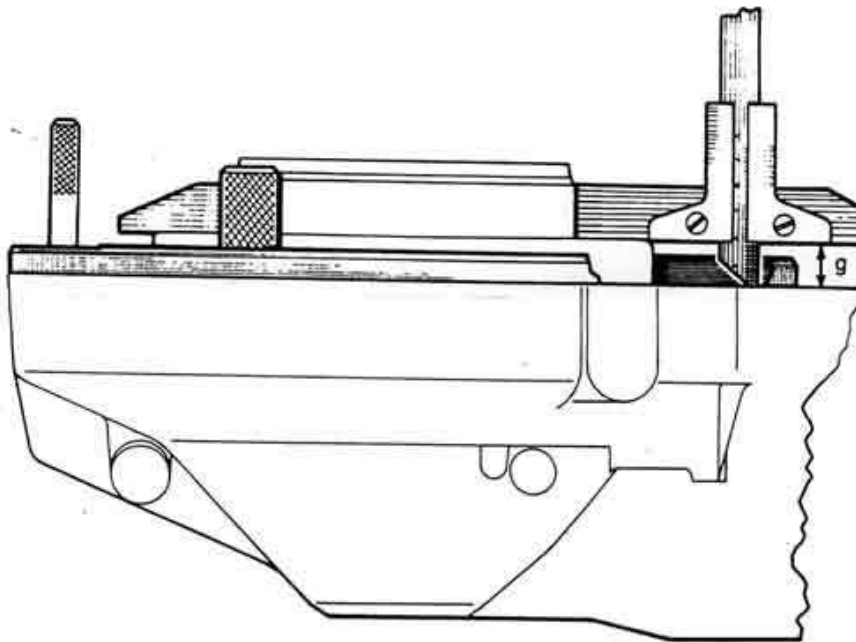
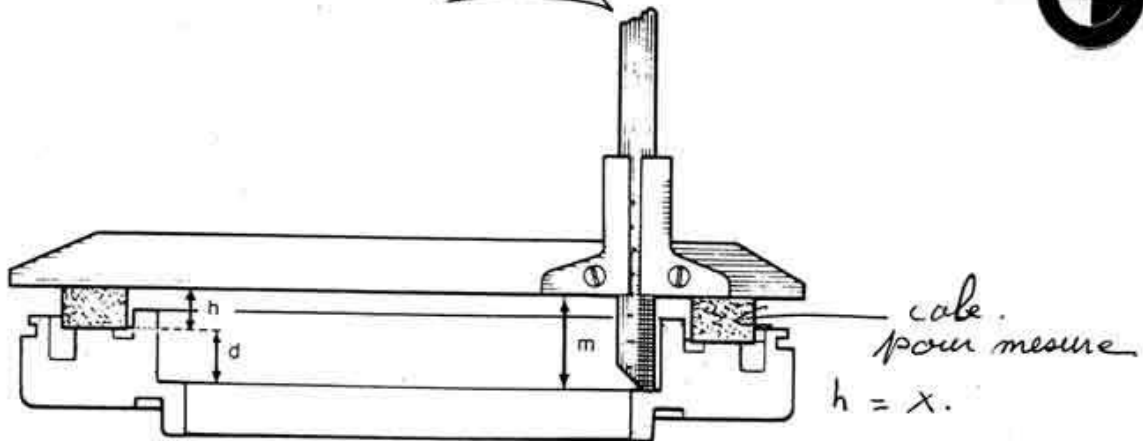

m	mesuré
- h	"
= d	
- g	mesuré
=	Jeu sans précontrainte
+	Valeur précontrainte
=	Epaisseur de la cale

**BMW Moto**

# Distance conique

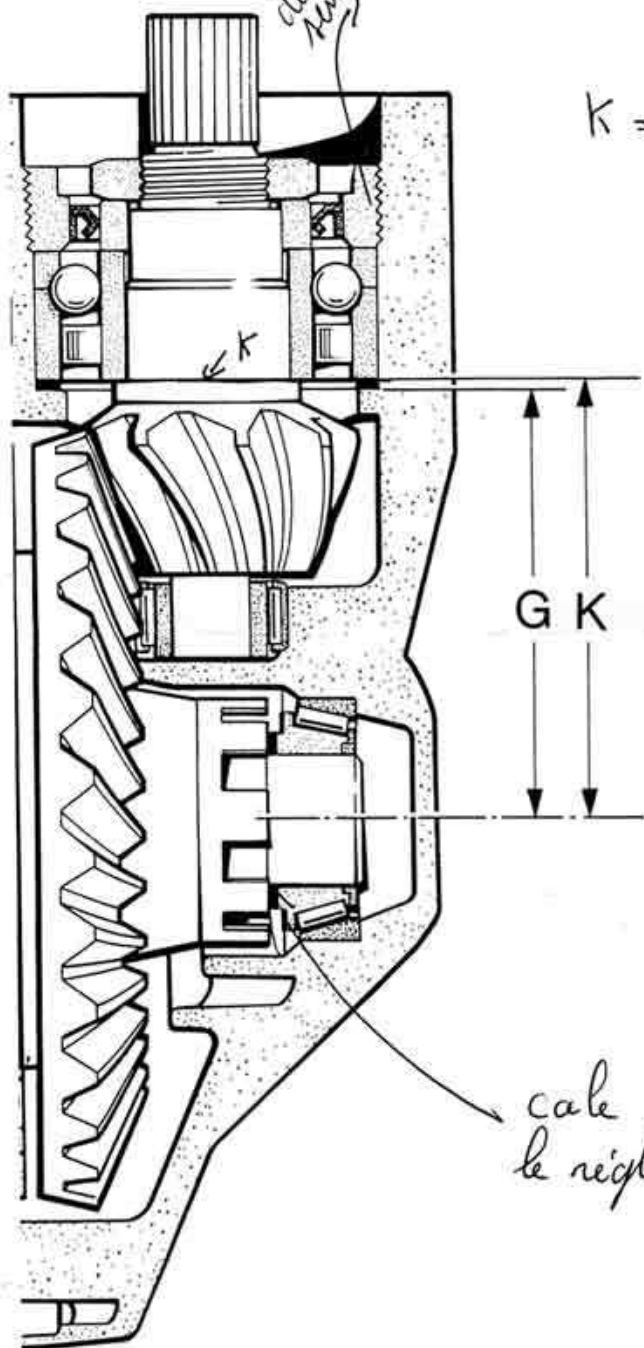

$G =$  cote de base des cartis

$$G = 75,50 -$$

$K =$  cote de base du pignon

$$K = 77,5$$

cafe technique

$$= K - G = 2 \text{ mm.}$$

cafe de réglage de l'extincteur  
le réglage se fait carton froid.



## Jeu entre dents

mesure en 3 points et faire la moyenne  
0,07 et 0,16 mm.

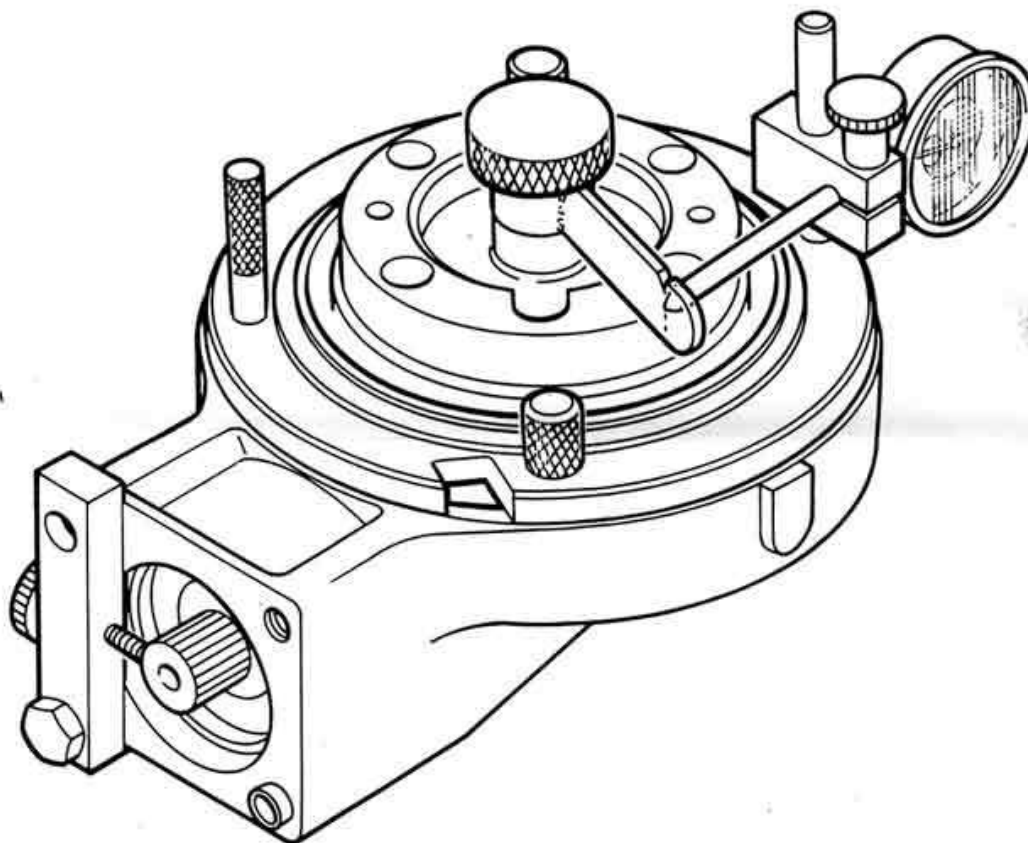

**BMW Moto**

---