

The Golden Age of HP Through Some of Its Masterpieces

Hewlett-Packard Signal Sources

History, Engineering, and Restoration

8640B, 3320A, 8012B, 8015A, 8165A, 3325A, 8160A

Giovanni Becattini



References

The following references are used in this book:

- [TEO] Tektronix Epic Oscilloscopes – Elektor Books
- [7KS] Tektronix 7000 Series – Elektor Books
- [TREG] Tektronix Oscilloscopes Restoration Guide – Elektor Books
- [HP1] Hewlett-Packard and its Voltmeters and Oscilloscopes – Quacktech
- [HP2] Hewlett-Packard Signal Sources – Quacktech
- [HP3] Hewlett-Packard Counters and Spectrum Analyzers – Quacktech
- [HP4] Hewlett-Packard Calculators, Computers and HP-IB – Quacktech
- [VRE] Vintage Radio Equipment – Elektor Book
- [MAC] Apple Macintosh – History, Engineering, and Restoration – Elektor Books
- [QT602] The Good Giant – Tektronix DSA 602A Oscilloscope – Quacktech
- [QT11KP] The Last Plug-ins – Tektronix 11000-Series Plug-ins – Quacktech
- [SCLI] Strumentazione Vintage – Edizioni C&C
- [QTCOL] Collins Classics – KWM-2, 30L-1 and 51S-1: History, Engineering, and Restoration – Quacktech Editions
- [QT324] Two Giants and a Shorty – Tektronix 323/324 - Quacktech
- [QTBYP] Become Your Own Publisher – Quacktech
- [QTHPSS] Hewlett-Packard Signal Sources – Quacktech
- [DAB] Digital but Analog – Quacktech
- [TG7] When Machines Learned to Write - Quacktech

- All rights reserved. No part of this publication may be reproduced or stored in any form or by any means, electronic or mechanical, without the prior written permission of the Author.
- The Author has made every reasonable effort to ensure the accuracy of the information contained herein but assumes no responsibility for errors or omissions, or for any loss or damage resulting from the use of this material.
- Most photographs were taken by the Author; others derive from commercially licensed or Creative Commons sources, clearly indicated where applicable.
- AI-assisted content disclosure – This book contains AI-assisted content used for language revision and for the creation of original illustrative material. All ideas, technical content, structure, and final editorial decisions remain entirely the Author's own.
- Some illustrations in this book were generated with the assistance of artificial intelligence tools, using original prompts and concepts developed by the Author. These images serve a purely illustrative and metaphorical purpose and are not intended to depict or reference any existing copyrighted characters, brands, or proprietary visual styles.
- Apple, Hewlett-Packard, Tektronix, Teletype, and other trademarks or logos mentioned in this book are acknowledged and remain the property of their respective owners.
- © 2025, 2026 Giovanni Becattini, Florence, Italy.

Table of Content

Introduction	3		
Table of Content	4	1977	33
Preface	11	1977 HP Signal Sources	33
		The Years of Change	33
Signal Sources	15	8640B Signal Generator	35
What Are Signal Sources?	17	Description	37
Understanding Old Equipment	17	A Technology Turning Point	37
Source Categories	18	General Specifications	38
Basic Types	18	Modulators	38
Waveforms	18	Spectrally Pure	38
Unicuique Suum	20	The Stability Issue	40
Pulse Generators	20	Most Intriguing?	40
Oscillators	20	Phase-lock Stability	40
Signal Generators	20	1991 8640B Price List	40
Function Generators	20	Much More Than Professional	42
Signal Sources Specifications	23	Designed to be Serviced	45
Specifications	23	The Circuit	47
Frequency Range	23	Stability	51
Frequency Accuracy	23	Output Circuits	51
Frequency Standards	24	The Cavity	52
Frequency Stability (Precision)	24	Construction	54
Signal Purity	24	Eight Years Between	54
Phase Noise	24	A Few Differences	56
Output Level	27	Misleading Keys	58
Power Accuracy	27	Gears	60
Modulation	27	The Counter	62
Pulse Parameters	27	Boards, The Upper Deck	64
Pulse Parameters Accuracy	28	Boards, The Lower Deck	66
Sweep	28	Details	69
Temperature Range	28	Spic & Span	70
Microprocessor: No / Yes	28	Restoration	70
Parameter Storage	30	Switches and Other Disasters	72
HP-IB Programming	30	The Purpose	72
The Years of Change	33	The Disaster	72

Table of Content (cont'd)

Oh no! The 8640B too!	72	Architecture & Circuit	113
Explanation of the Puzzle	73	The Synthesized Sinewave Oscillator	113
The Attenuator's Secrets	74	Ranges	113
OUTPUT LEVEL Knob Adjustment	76	Frequency References	113
Output Level Adjustment	78	Direct vs. Indirect Frequency Synthesis	114
Troubles Never End Today	78	Highest Range	114
Fixing The Attenuator Mechanism	78	Lowest Ranges	114
		Why This Approach?	116
Using the 8640B	80	The Vernier	116
First Measurement Attempts	80	Signal Purity	117
More Measurements	82	Controlling the Amplitude	118
Pulse Modulation	84	Performance	118
More Using Modes	87	Amplitude Control Circuit	118
		Thermopylae?	120
More Faults and Fixes	89	High School Reminiscences	120
Oh No, Something Broke!	89	Thermopiles	120
Usual Suspected Characters	89	A Precision Attenuator	122
Block Diagram	90	Model 3320B's Attenuator	122
Hey, but I Also Have Option 003!	90	Servo Loop	122
Which Manual Describes It?	90	The Digital to Analog Converter (DAC)	124
A Useful Option	90	Low Frequencies	124
Price	91	The AC to DC Converter	124
Tracking Down The Fault	91		
The K1 Relay	91	Construction	126
Just in Time	92	Caged Boards	126
The Repair	97	The Leveling Board	128
Results	97	Lower Deck	130
The Repaired Option 003	98	Front Panel Gears	132
		Front Panel Switches	134
Conclusions	100	Boards	138
A Summary About Manuals	100	B-Side	144
		Repairs	146
3320B Frequency Synthesizer	103	Frequency Problems	146
Description	105	The Mystery of the 74L86	148
Pricing	105	Second Problem: the Amplitude	148
The Essence of the 3320B	105	Finally, a Mechanical Problem!	150
New Requirements	106		
Basic Instruments	106	The Unlucky Brother	152
New Needs	106	Two Brothers' Story	152
Answering the Call: New Concepts	108	The eBay Find	152
Programmability	110	Curiosity Is Not Always Feminine	152
Automatic Control	110	I Want to Fix You	152
They Didn't Know (?)	110	The "Coward Strategy" Wins Again	154

Mechanical Restoration	154	Donkeys Go To Study	188
Label Makers to Death	154	Ltspice	188
The Result	154	Building Blocks	189
8015A Pulse Generator	157	Constant Current Sources	190
The Crowded 80xx Family	158	Classic Current Source	190
A Wide Range of Pulse Generators	158	How Does It Work?	190
"Confused" Products	158	Simplified Version	192
Family Architecture	158	Constant Current in the 8012B	192
Our Guests in This Books	160	Schmidt Triggers	194
Not Impressive	160	Simulating a Schmidt Trigger	195
Pulses Quality	160	A6 Board	197
Description	162	Pulse Shapers	198
It Had to Happen	162	What Does It Mean To Shape?	198
What It Is	162	How Does It Work?	198
Not Cheap	162	Fixing the 8015B	202
Sliding Controls	163	The Way It Should Be	202
The Sliding Fever	163	The Devil's Tail	204
Output Control	164	The Turning Point	204
Controlling Output Amplitude	164	Why Did It Work?	204
Not To Be Used Alone	164	Not All The Mysteries Have Been Solved	205
Construction	166	Backlash!	206
Internal Organization	168	The Choked Schmidt Trigger	206
Lots of Heat	168	Conclusions	207
50 Ohms Are Few	168		
Perforated	170	Volume 2B	209
A Dead Look	170		
Heat Everywhere	171	8165A Signal Source	211
Stability Problems	171	Description	213
The Circuit	172	Hate or Love?	213
Amplifiers	172	HP Journal	213
Controlling the Gain	172	The Dark Ages	215
Amplifier Boards	174	Not Everything Was New	215
Timing Circuits	176	Not Everything Was Good	215
What to Do with It?	179	Specifications	216
8012B Pulse Generator	181	Stability, Accuracy and Resolution	216
Specifications	182	Other 1979 New Equipment	216
Faults like Roadrunners	184	Multiple Waveform Generation	218
Perseverare Diabolicum	184	Operating modes	218
The Worst Ever?	184	Option 002	218
Architecture	186	Output Capability	219
A Little Vintage	186	HP-IB Programming	220
The Hardware	186	Prices	220
The Circuit	188	The B-Side	222
		Architecture and Circuit	224
		More Than Ten Decades	224
		Moving to a Switchless Design	224

Table of Content (cont'd)

Verniers Again	224	8165A Circuit	260
Block Diagram	225	The Trigger Itself	260
An Empty Box?	226	Current Regulation	263
Complex Circuits	226	Simplified Current Regulators	263
Modular Construction	226	VCO Control	264
Microprocessor Based	228	Obey My Commands	264
Setup Saving	229	Checking the DAC	264
Reverse Engineering	231	Direct VCO Control	265
Frequency Generation	232	Closed Loop Operation	266
One of the First PLL-based Instruments	232	Electrical Connections	268
From 1 kHz to 50 MHz	232	Another Error	268
Basic Phase-Locked Loop	234	Phase Noise	268
Settling Time	234	General Sine Shaping	270
Multiple Loops	236	I.e., Not All Crazy People Are In The Asylum	270
Further Explanations	236	Diode Sine Shaping	270
Frequency Generation Below 1 kHz	240	Rubber Bands	271
Current Sources	242	Simulation Results	271
Used Everywhere	242	8165's Sine Shaping	272
Then Is Not Today	242	A Different Circuit	272
Opamp Current Sources	242	HP Journal Says...	272
Opamp Negative Constant-current Sources	242	The Edited Diagram	272
How Does It Work?	243	More on Sine Shaping	274
Opamp Positive Constant-current Sources	243	My Sine Shaper	274
Voltage-Controlled Oscillator	244	Yet Another Failure	274
Three VCOs Implementations	244	The Output Amplifier	276
HF VCO	244	Four Functional Sections	278
Why This Solution?	246	Verniers	278
Generating Ramps: an Overview	248	Pseudo-Verniers	279
Covering the Full Range	249	8165A Verniers	279
A Closer Look at the Circuit	250	Digital Verniers Basic Cell	280
Did They Pay for Transistors?	250	Inner Working	280
Ramp Capacitors	250	A Bigger Picture	282
Currents Control	250	Checking and Repairing	282
Current Redirection	252	Other Sections	284
Capacitors Reference Ground	254	Power Amplifier	284
HF Compensation	254	Attenuator (Service Sheet 4B)	286
Checking Currents	256	Offset Generator (Service Sheet 4C)	287
VCO Trigger	258	Control & Power Boards	288
Basic Trigger Scheme	258	Microprocessor Section	291
Modified Trigger Circuit	258	As Usual	291
Steady States	258	Microprocessor Control System	291
Transients	259	uP Tasks	291
The Third Transistor	259		

Acceptors	292	Microprocessor Based	329
How the Bus Works	292	Block Diagram	330
Possible Addresses	293	Understanding PLLs	333
Operating the 8165A	293	Integer-N Phase Locked Loop	334
Batteries	294	3325A Output Signal	335
The Keyboard(s)	296	Fractional-N Phase Locked Loop	336
A7 Counted Bursts Board	300	Fractional Frequencies	336
A11 Sweeping Board	302	More about Phase Detector	337
Fixing the 8165A	304	Fractional-N PLL Basic Principle	338
Seek on Arrival	304	When is an Extra Count?	340
The King of Failures	304	What Value Is Added?	341
Initial Situation	304	Why This Is Not Enough	341
Oscillations	304	Phase Detection and Integrator Action	342
The Approach	305	Analog Phase Interpolation	342
The Magic 100 Ohm	305	Implementation	343
A Digression	305	Fractional-N Phase Locked Loop	344
The Circle Narrows	306	e-Verniers	346
Calibration Notes	308	DAC Control	346
My Less Preferred Operation	308	The DAC itself	346
Some Notes	308	Six Controls	347
Frequency Problems	309	Amplitude Loop	348
A Comparison	311	On the 30 MHz Reference	348
Time Doesn't Pass in Vain	311	The Interesting TP4	348
Conclusions	312	Closed Loop	348
Beginning of Love?	312	Auto Calibration	349
Complexity	312	Auto Calibration Disable (ACD)	350
A Lesson from the History	312	Using TP4	350
3325A Function Generator	315	Not Only Sine	352
Description	316	Sweeping	355
New Requirements	317	Frequency Sweep	355
The Situation	317	3325A Features	355
Too Expensive	318	How Does It Do?	355
The New 3325A	318	Construction	356
Lightweight!	318	Top & Bottom	358
A Trendy Front Panel	320	The Keyboard	360
Fractional-N Frequency Generation	322	External Connections	362
Synthesizers Take Over	322	As Many As 12 Connectors	364
Options	324	Standard Signal Connectors	364
Option 001 Oven High Stability	324	Signal Connectors with Option 002	364
Option 002 High Voltage Output	325	Sync Connector	365
Specifications	326	Other Rear Panel Connectors	365
Specifications	326	Connectors' Waveforms	365
Harmonic Distortion	326	Connectors' Map	366
Architecture & Circuit	329	Screenshots of Output Signals	368
		Fixing the 3325A	370
		Easy to Work On	370
		Urgent Questions	370
		Power Supply	370

Table of Content (cont'd)

Fault Types	372	Building Blocks	406
Checking the 30 MHz	372	Interconnections	406
Checking the Synthesizer	373	A Flexible Structure	408
Checking the D/A Converter	373	Time Interval Blocks	408
Checking the Mixer	374	Delaying Circuits	408
Cooperation	376	Manuals	409
Last Notes	378	More Details	410
Conclusions	380	Structure	412
8160A Pulse Generator	383	Modular Organization	412
Introduction	384	Removing the Boards	412
You Are Mad	385	Beware of Connectors	412
Preconceptions?	386	The Boards	415
It Arrived!	386	Position-free?	415
Wonders Inside	386	Why Should I Do This?	415
First Attempts	388	A140 Board, Slope Generator	416
Description	390	A126 Board, Very Short Delays	418
Introduction	390	A127 Board, Short Delays	420
Top Expensive	392	A128 Board, Long Delays	422
Prices Today	392	A150 Board, Output Amplifier Control	424
Prices at That Time	393	A151 Board, Output Amplifier	426
Precise Control	394	A2 Board, Microprocessor	428
Precision Pulse Generation	394	A4 Board, Display & A3 Board, Keyboard	430
Accuracy & Precision	394	Using the 8160A	432
New-trend Design	397	Fantastic!	432
Microprocessor-based	397	Caveats	432
Counted Burst	397	Family Photos	434
HP-IB Programming	397	Some Shots	435
The New uP Board	398	Repairing the A126 Board	436
It Can Store Setups	400	Good Luck	436
Parameter Storage	400	The Dead Chips	436
Active Verniers	400	Bad Luck	436
Learn Mode	400	Waveforms	438
HP Journal	400	A126 Board Test Point Waveforms	438
Architecture & Circuit	402	Narrowing the Circle	441
Accurate Rate Generation	402	Crime Scenes	441
New Secrets	402	Poor's Man Repair	442
Don't Question Me, Please	405	Finding the Culprits	442
Time Interval Blocks	406	Confirmation	442
		Spare Parts	442
		More to Fix?	444

The Problem	444
Usual Suspects	444
Catastrophe?	444
The Solution	445
Repairing Displays	446
Still a Novelty	446
How To Replace Them?	446
Another Opinion	449
Another Mad Collector with Another 8160A	449
Conclusions	450
Love Stories	450
Technical Solutions	450
A Great Classic	450
Some Tests	453
Comparing Produced Waves	454
Phase Noise @ 20 MHz.	454
Phase Noise @ 1 MHz	454
A Road Test	454
Spurious Harmonics @ 500 kHz	456
Fractional-N Wins	457
8165A Dual Mode	458
Conclusions	458

Note

Depending on the Print-on-Demand provider, a book of this length may not always be available as a single physical volume. For this reason, the present work, originally conceived as one continuous book of approximately 450 pages, may in some cases be issued in two separate parts:

- Volume 1: 8640B, 3320A, 8012B, 8015A
- Volume 2: 8165A, 3325A, 8160A

This division is purely practical and is required only by certain production constraints. In editorial terms, the work remains a single volume, with a continuous structure and a unified conception throughout. Accordingly, only one Table of Contents is provided, and it appears at the end of the second part, exactly as it would in the complete single-volume



Preface

For generations of engineers, Hewlett-Packard—simply “HP”—set the standard for electronic instrumentation. Its instruments were not merely tools, but symbols of precision, reliability, and intellectual rigor. (When it came to oscilloscopes, many of us—myself included—often preferred Tektronix, but that is another story.)

Founded in 1939 by Bill Hewlett and David Packard, HP grew from a small Palo Alto garage into one of the most respected electronics companies in the world. Over the decades, it shaped the way measurements were made and understood, establishing reference points for generations of engineers and scientists.

This volume is part of the Technical Art Books collection and belongs to the series HP: The Golden Age – An Era Told Through Electronic Masterpieces, devoted to exploring the most significant period of Hewlett-Packard’s production through a selection of representative instruments, calculators, and computers. Rather than aiming at completeness, this series presents a portrait of an era through emblematic examples of electronic design.

This specific volume is dedicated to what Hewlett-Packard called signal sources: an exceptionally broad family of instruments—including signal, pulse, and function generators—produced in a vast number of different models, of which this book presents only a selected group of representative examples.

More than a catalog, this book is intended as a historical and technical journey, combining images, technical investigation, personal experience, and practical restoration, in order to preserve the memory of an exceptional generation of instruments and of the era that produced them.

*Giovanni “Gianni” Becattini
giovanni.becattini.books@gmail.com*

*To my wife
and my family*

Voltmeters and
Oscilloscopes

Signal Sources

Counters and
Spectrum
Analyzers

Calculators,
Computers,
and GPIB

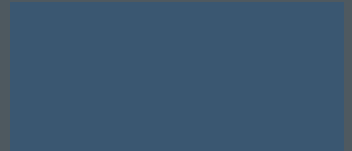

Hewlett-Packard

Voltmeters

Oscilloscopes

Signal Sources

Counters

Spectrum Analyzers

Calculators

Computers

HP-IB

Section

Signal Sources

A primer on the different types of equipment you will see in the chapters that follow

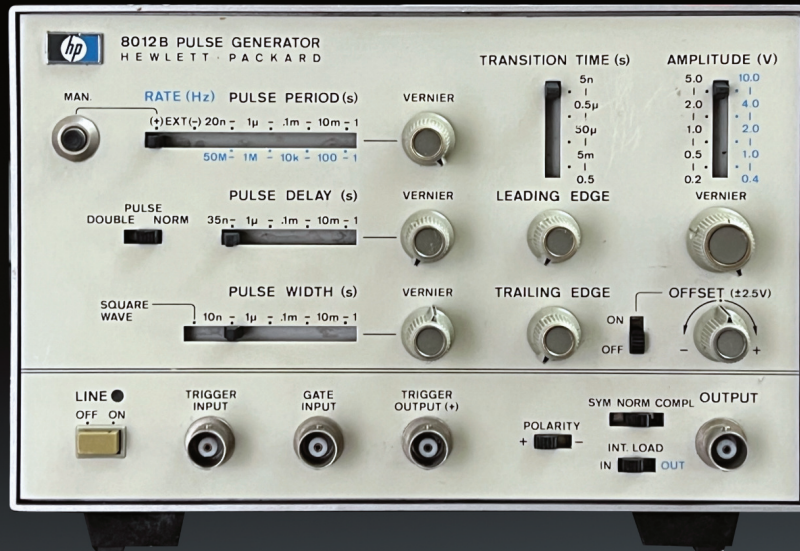

8012B Pulse Generator

1975

The 8012B is another product from Hewlett-Packard's mid-seventies line. It offered many of the features of the 8015A in half the space. Its construction was slightly better than its bigger brother.

Section:

Signal Sources

Subsection:

8640B Signal Generator

A true classic masterpiece in signal generation

Designed to be Serviced

Actually, the mainframe carries two devices: a signal generator and a frequency counter combined together to give you an accurate readout of the output frequency, very useful and far superior to similar equipment where a separate counter or complicated reference procedures are needed.

It is not often that you find an instrument so perfectly designed to be easy to maintain. Francesco told me that when the Army decided to order a military signal generator, very few modifications were required, and I can believe that. In addition to the modular design, clear instructions are provided for each subassembly. Most of the electronics is contained in removable boards, and each of them has its own test points easily accessible on the upper edge of the board itself, and so do the adjustment trimmers.

While I was writing these notes, an 8640B Opt. 323 (aka AN/USM 323) is available at Radio Surplus Elettronica, one of the best Italian surplus shops. You can find them easily on eBay.

REMOVE COMPLETE ASSEMBLY
REMOVE FRONT EXTRUSION
REMOVE FRONT WINDOW
AND REMOVE 4 CORNER SCREWS
CONNECTORS BELOW DECK

Gold-plated
printed circuit
boards





A26A2 AM Offset
Pulse Switch Board

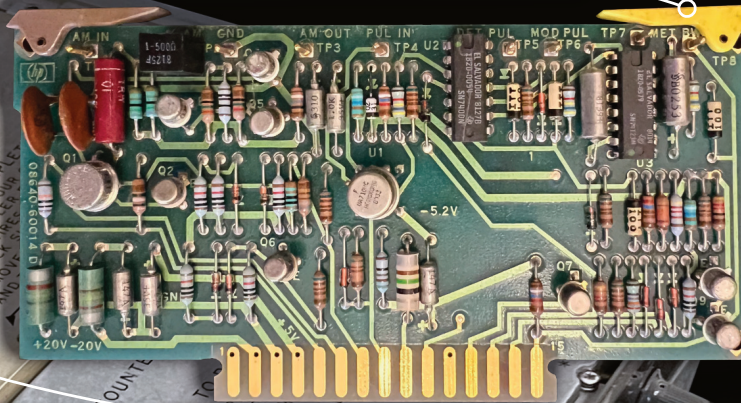

Boards

Upper Deck

A4 Meter Annunciator
Drive Board

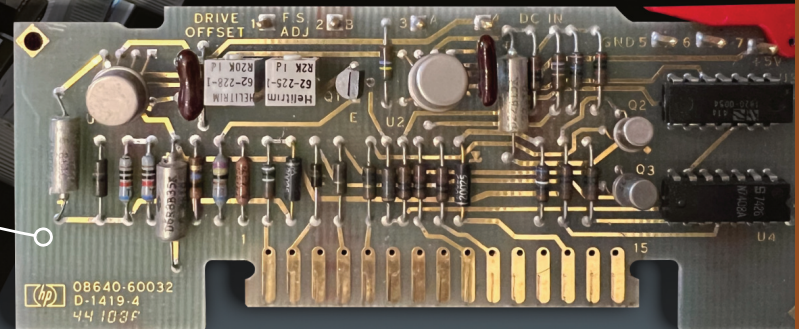

A2 Meter/Switch Board

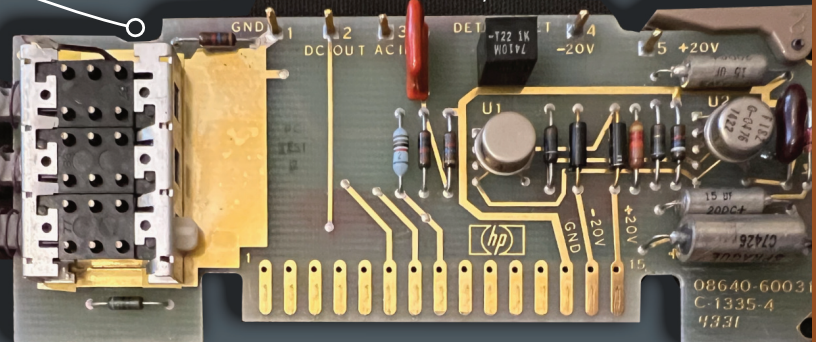

A26A4 AGC Amplifier

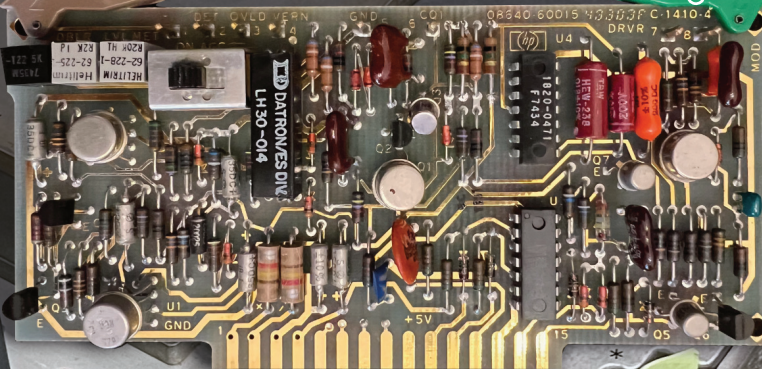

- ❶ The brass gear mentioned in the text. Loosen it to align the knob scale.
- ❷ This nylon gear reports the vernier movement to the brass gear.
- ❸ This white disk carries the line used as scale index and rotates with the vernier movement.

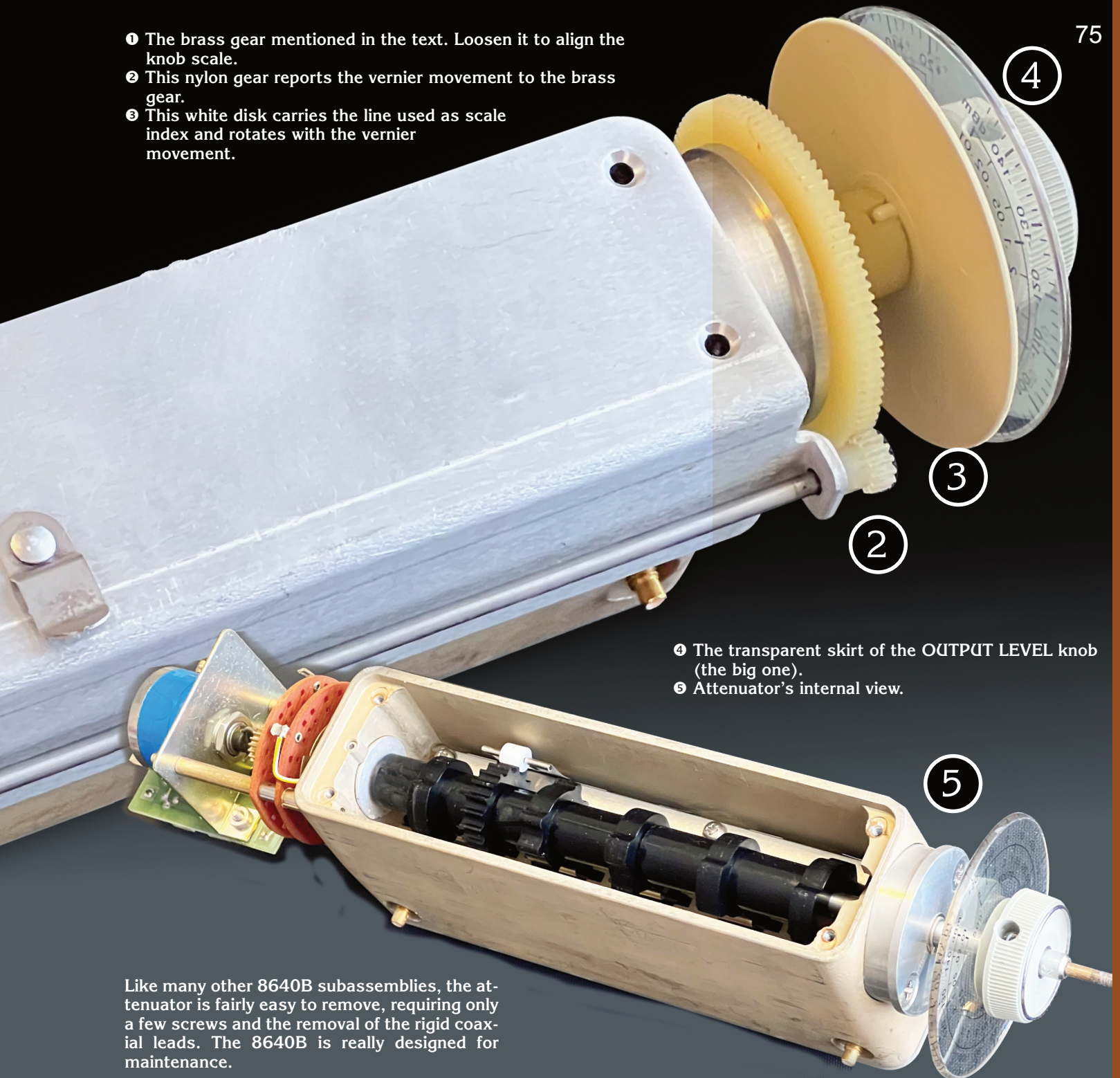

- ❹ The transparent skirt of the OUTPUT LEVEL knob (the big one).
- ❺ Attenuator's internal view.

Like many other 8640B subassemblies, the attenuator is fairly easy to remove, requiring only a few screws and the removal of the rigid coaxial leads. The 8640B is really designed for maintenance.

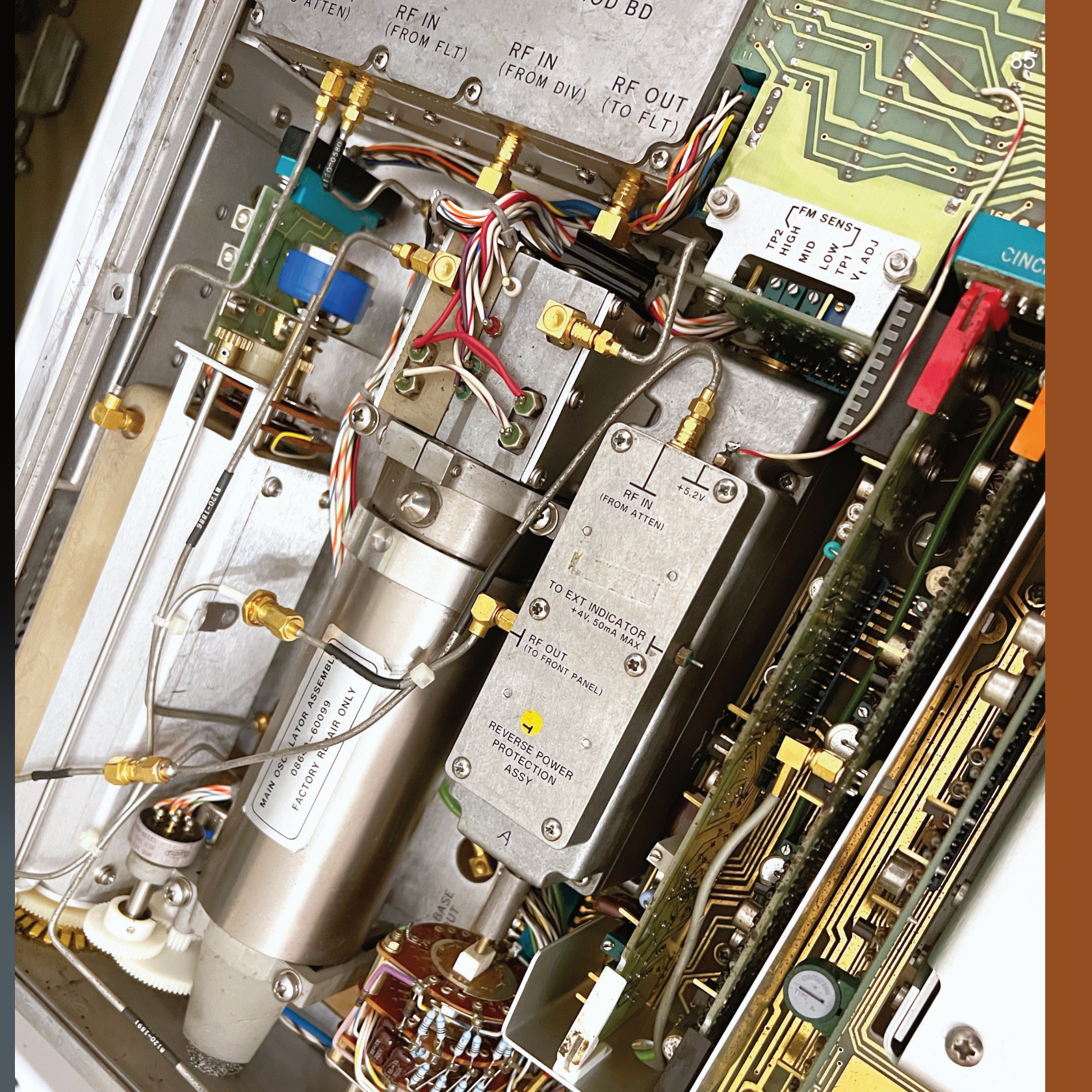

MAIN OSCILLATOR ASSEMBLY
0867-60099
FACTORY REPAIR ONLY

RF IN (FROM ATTN) +5.2V
TO EXT INDICATOR +4V, 50mA MAX
RF OUT (TO FRONT PANEL)
REVERSE POWER PROTECTION ASSY
A

FM SENS
TP2 HIGH
MID
LOW
TP1
V1 ADJ

RF IN (FROM ATTN)
RF IN (FROM FLT)
RF IN (FROM DIV)
RF OUT (TO FLT)

38TFC0218

168TFC0218

CINC

85

The **3320B Frequency Synthesizer** is a very interesting instrument. Apart from its peculiar user interface, there are at least three good reasons for saying so:

- Introduced in 1972, it was one of the first signal generators based on frequency synthesis;
- It was among the first to offer **remote programmability**, even as an option;
- It featured a **programmable attenuator** with an impressive 0.01 dBm step (available only in the “B” version, as the 3320A had a conventional potentiometer).

It was not the first synthesized and programmable HP generator; the prestigious 8660A, for example, had already appeared in 1971, but it was prohibitively expensive. Thanks to its lower price, the 3320B could reach a much wider audience, and for this reason it can be considered the first truly “popular” synthesized signal generator.

Pricing

We are talking about Golden Age Hewlett-Packard products, not peanuts, so do not expect prices comparable to today’s Chinese gadgets. At the time of its introduction, the “entry-level” 3320A—i.e., without programmable amplitude control—was priced at \$1,900, while the 3320B cost \$2,400, equivalent to \$18,038 in 2024.

The GP-IB option was not available in 1972 and appeared in 1973 as Option 007, simply called “ASCII Remote Control.” It cost \$595, bringing the total price to \$22,510.

The Essence of the 3320B

For that price, however, you obtained an instrument capable of controlling both frequency and amplitude by directly setting the desired digits, either via the front-panel controls or through a remote command—something that most signal generators of the time simply could not do.

3320B Frequency Synthesizer

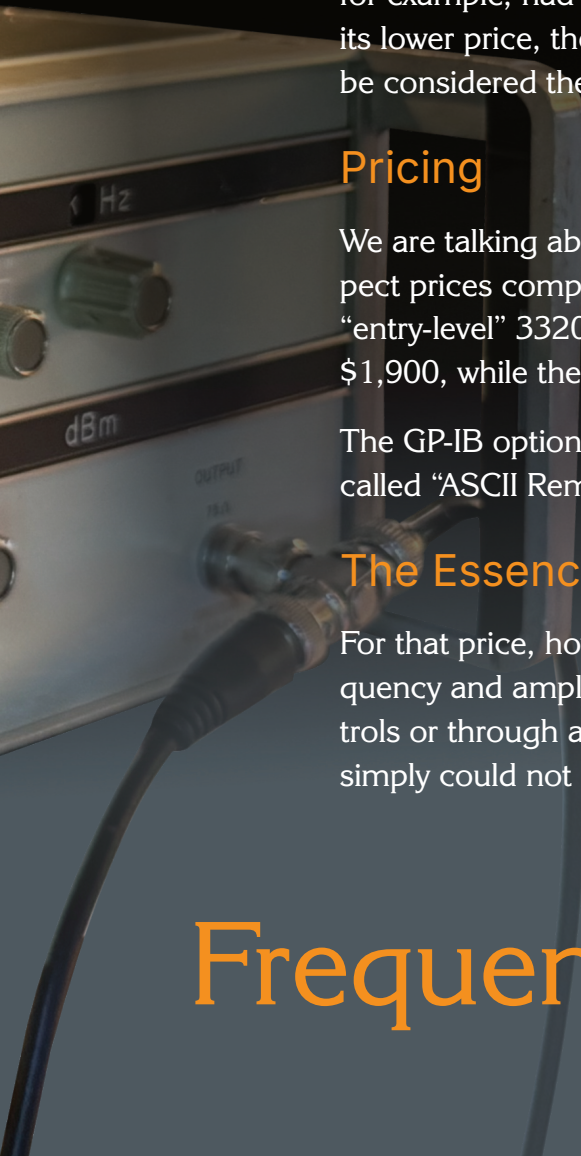

① Phase detector output adjusts voltage-tuned oscillator (VTO) to frequency that is N times 10-kHz reference frequency f_{ref} . In response to front-panel frequency controls, controller sets $\pm N$ block, a preset digital counter, to count down VTO output cycles by factor of N . Controller also sets pre-tune digital-to-analog converter to produce DC that tunes VTO close to desired frequency, speeding up restabilization of phase-lock loop when large changes in frequency are made.

② Simplified block diagram of Models 3320A and 3320B frequency generating circuits shows first two of five divider circuits (seven optional) that reduce span of local-oscillator frequency f_{lo} in decade steps. Switches S2 and S3 are set here to give output range of 0.000-1.299 MHz. To give finer resolution in frequency selection, switch S1 substitutes vernier signal f_v for 10-KHz reference f_{ref} .

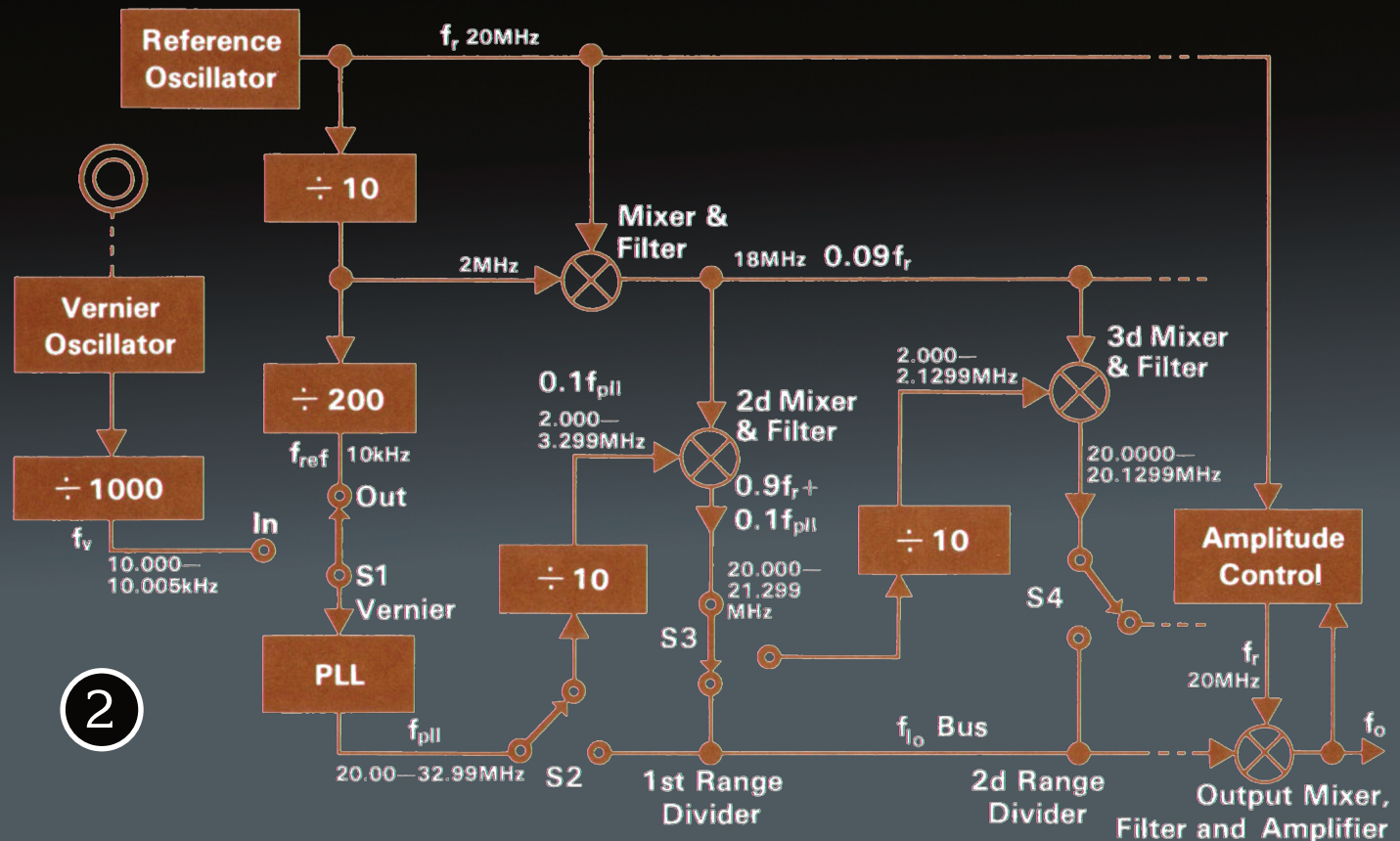
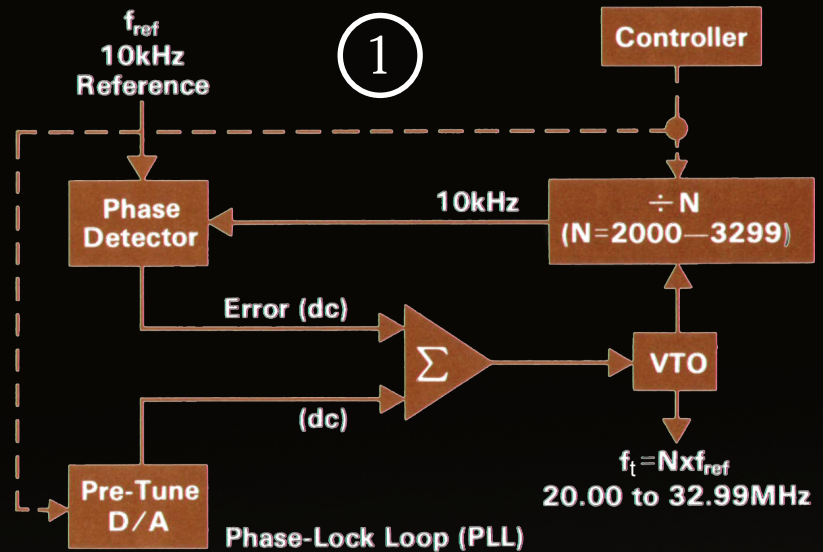

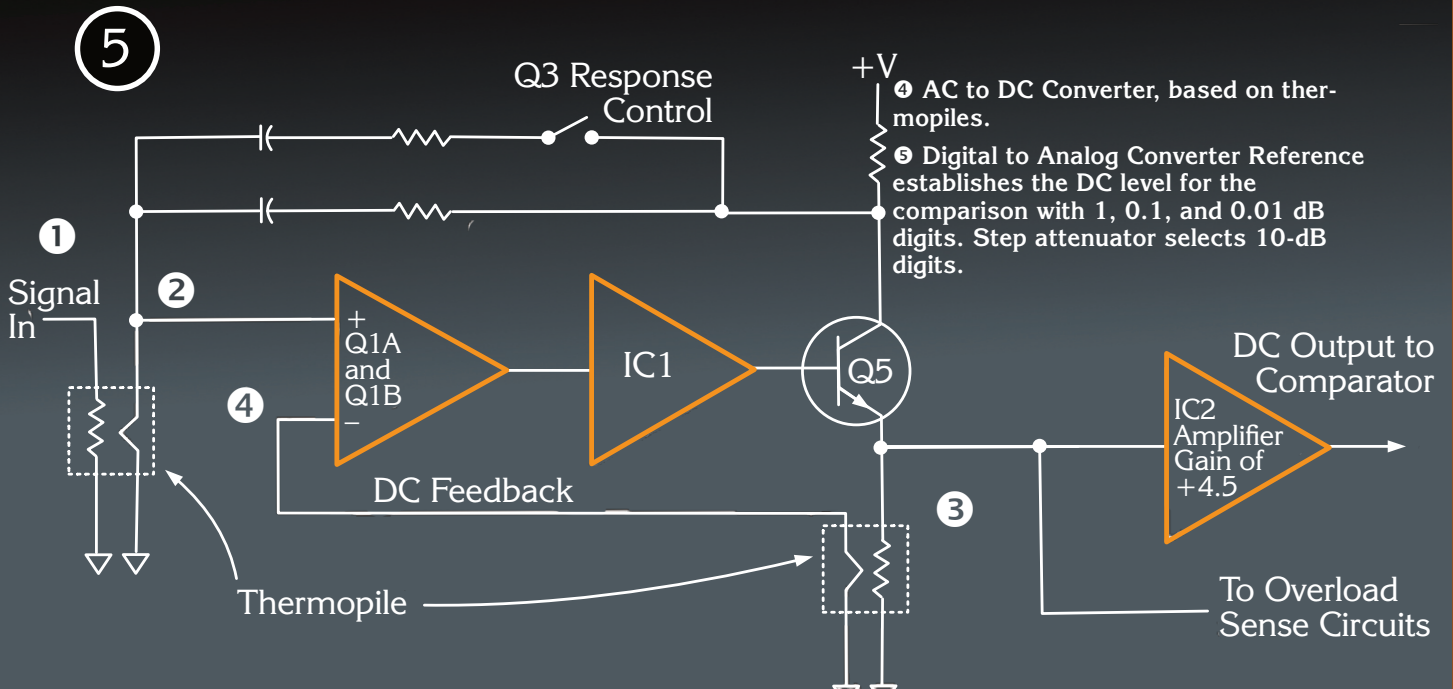
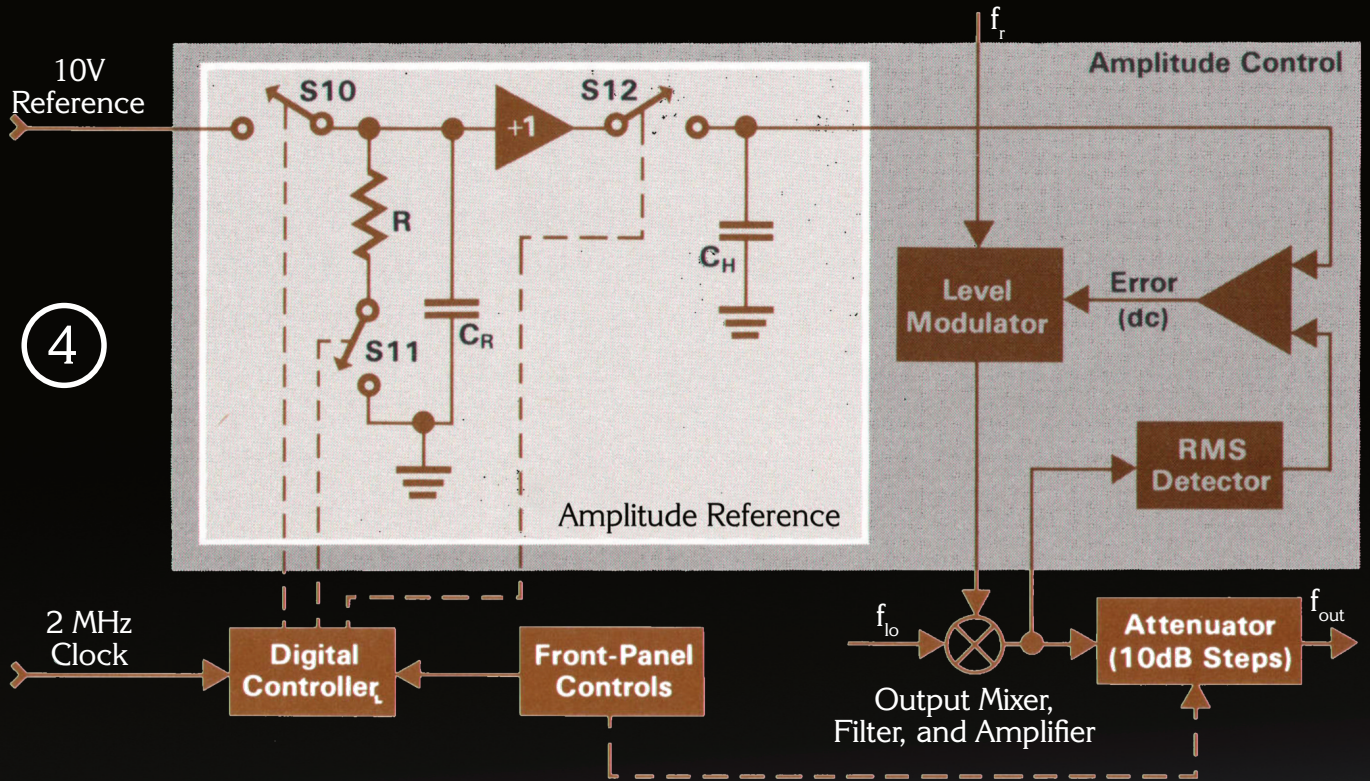

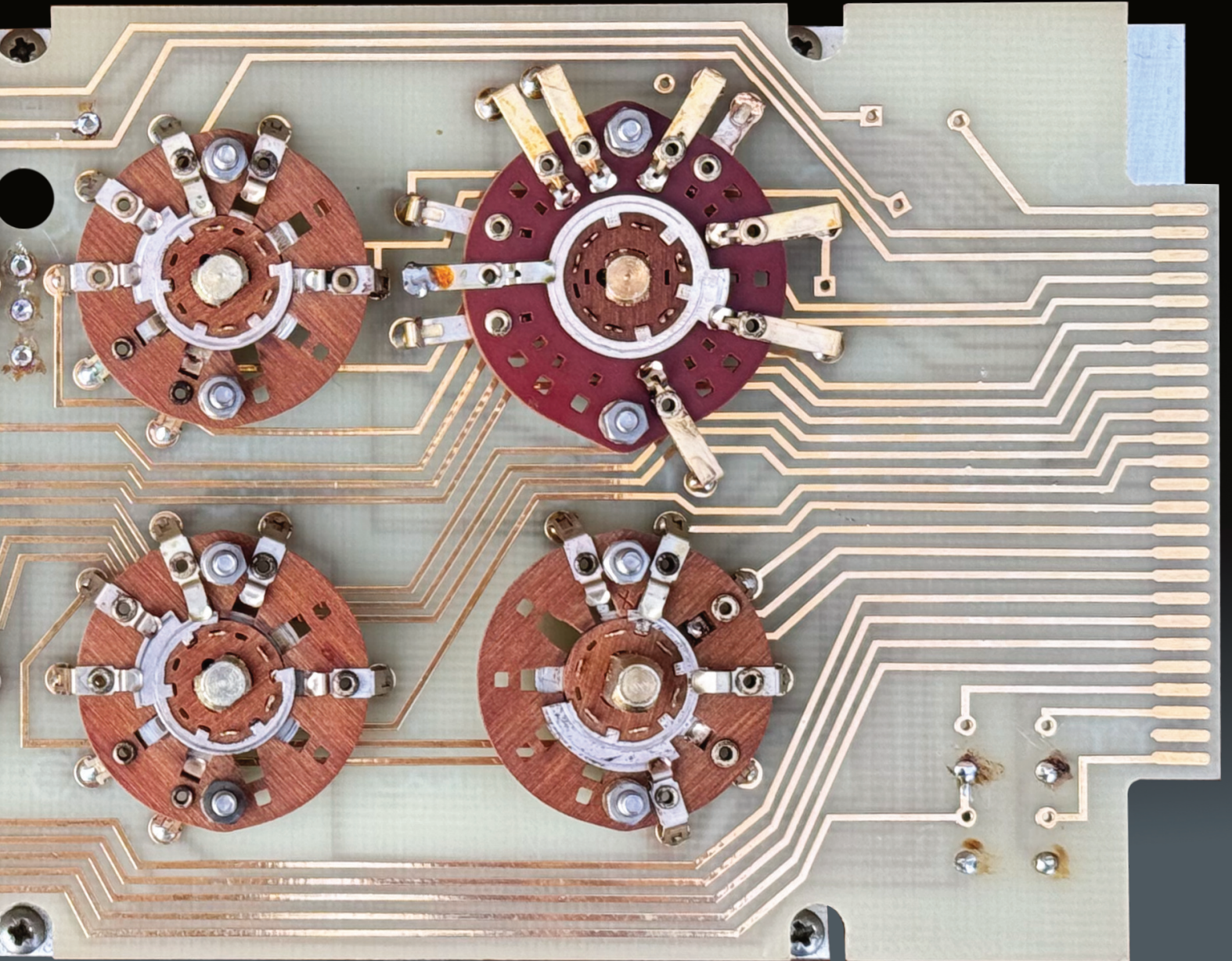

External Phase Lock: Input
for Reference 5 MHz
External Oven or External
Phase Lock Signal.

Pass-low Filter - I could not
find information about it.
Probably an option.



Remote input connector
for options 003, 004,
and 007 (BCD and GPIB)

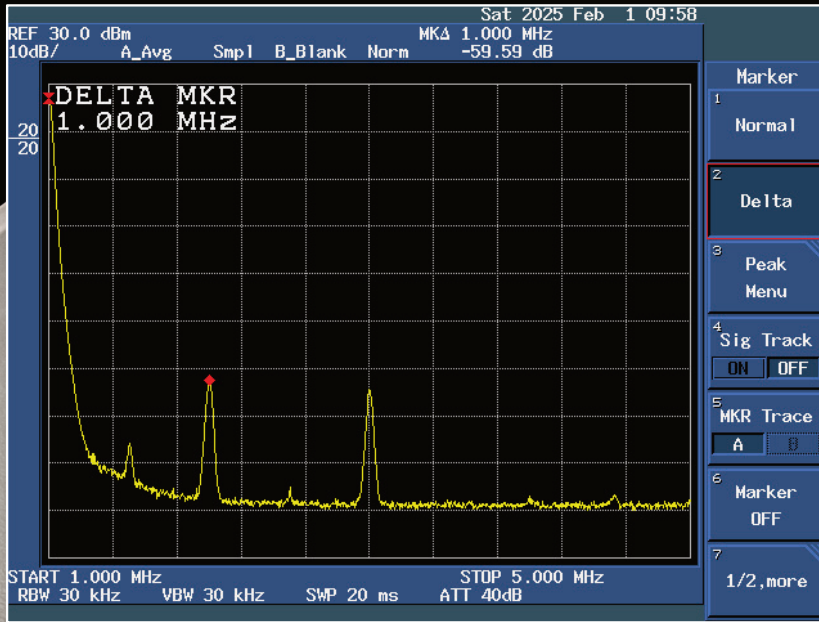

Photo: the 3320B bought as a scrap on eBay for 36 euros, completely restored. Note the “50 Ω” label on the output connector (the first described here has the 75 Ω option). This one has also the 04 option for remote BCD programming and the 06 which adds two lower frequency range, 100.0 Hz and 10.00 Hz, yielding greater resolution for low frequency outputs.

Here on the left is the promised harmonic distortion test: at full output amplitude (29.99 dBm), any harmonic-related signal from 100 kHz to 1 MHz must be less than -50 dB. As you can see, we are at 1 MHz with about -60 dB, so we are well within the specification.

RESIZER

2

0

0

0.6

MHz

VERN OUT

00

VERN IN

XX

-1

0

.

2

0

dBm

LEVELING

ON (>10Hz)

OUTPUT

50 Ω

CAUTION:
D.C. COUPLED

30 dBm? If you think, it is exactly one watt, not a negligible output power for a signal generator. You could use it also as a QRP transmitter!

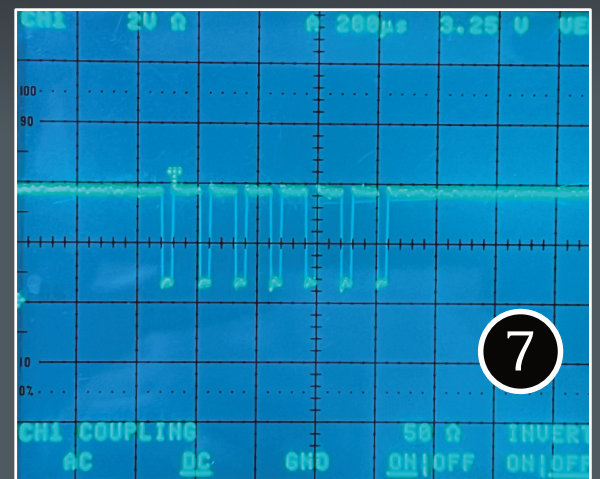
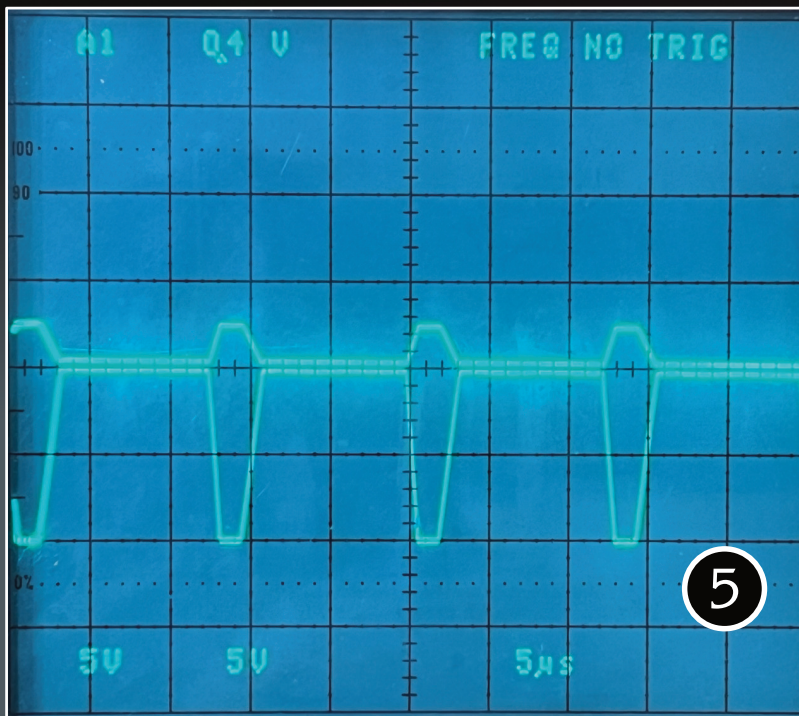
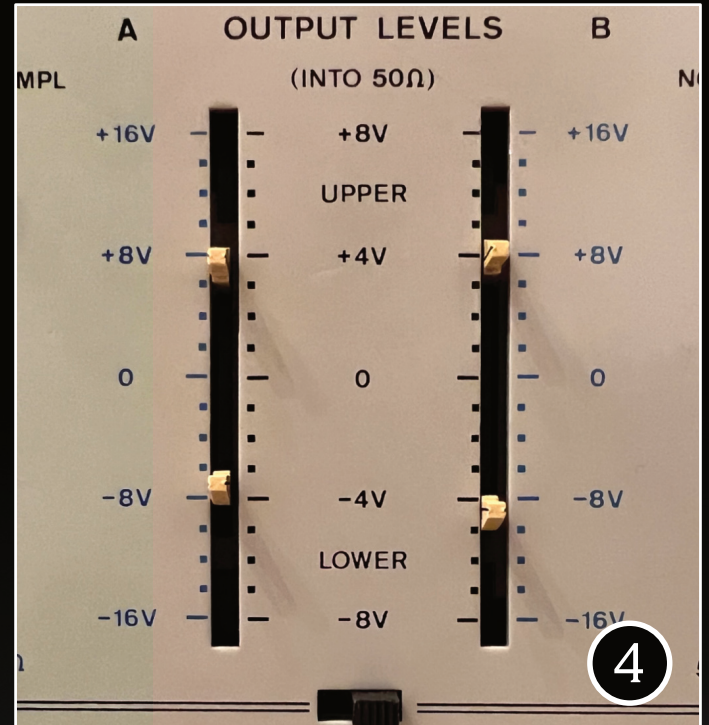
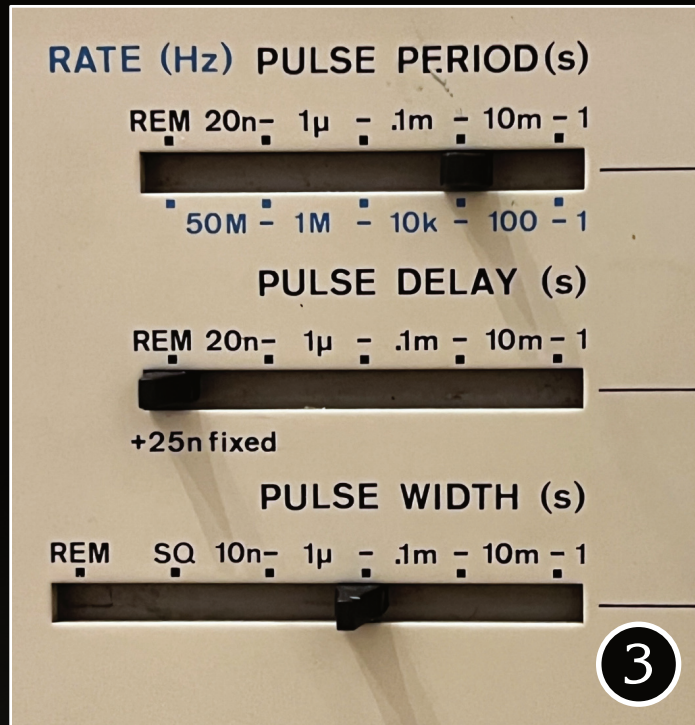

Each 8015A includes two amplifier boards, named A2A and A2B, one for each output channel.

Like most of the other boards, the amplifiers are made up with discrete components. The ICs are just arrays of transistors, not some form of more complex circuitry.

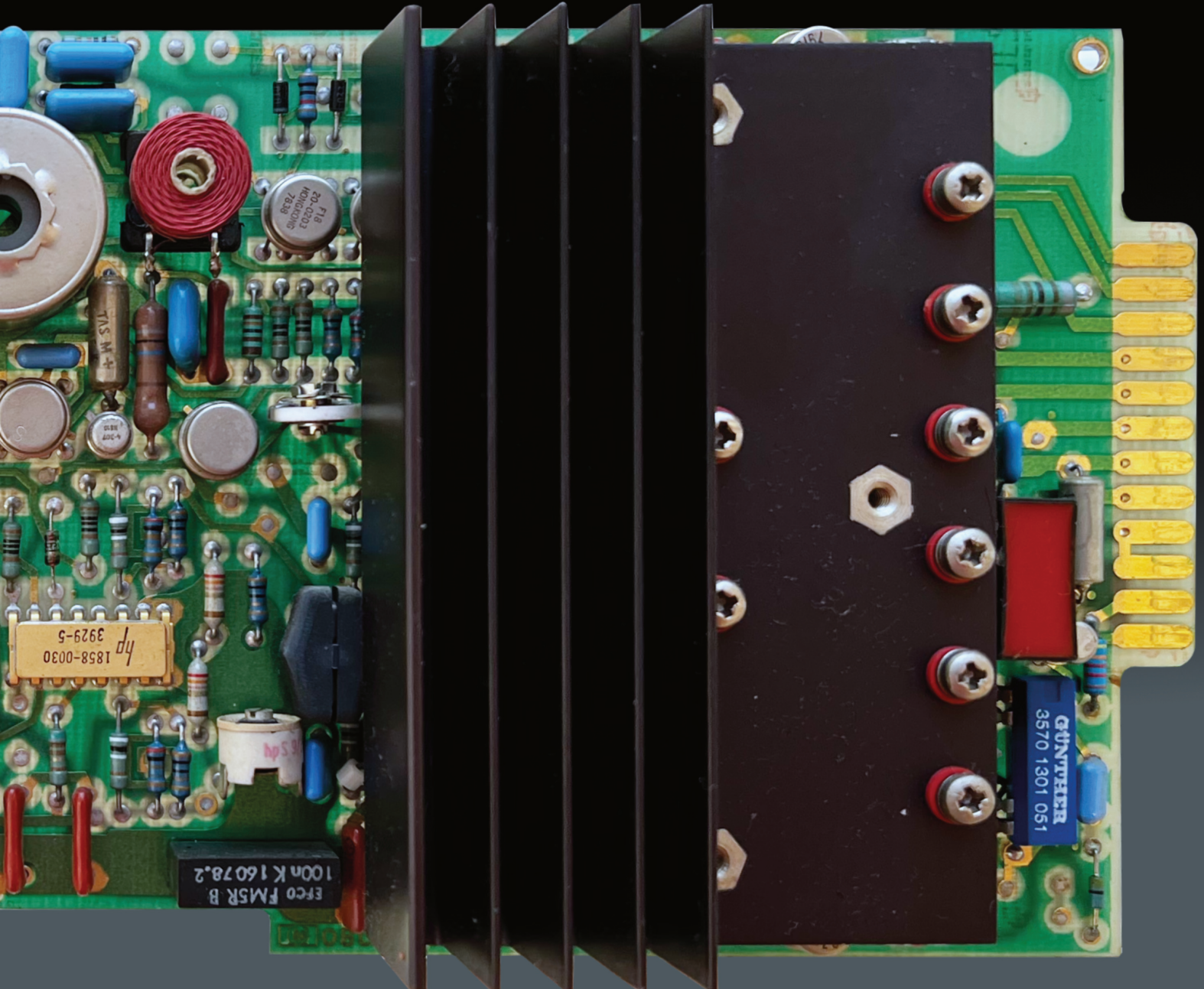



Ves

LOW to HIGH transition: As V_{in} increases, T1 begins to steal part of T2 base current, so T2 begins to turn off, and so its emitter voltage starts to fall. But this increases T1's base-emitter voltage, so T1 turns on more quickly. The positive feedback snaps the circuit into a state where T1 is on and T2 is off. V_{out} is now close to $+V$.

HIGH to LOW transition: T1's emitter voltage now is determined by its emitter current. When V_{in} falls to about 0.6v above this value (call it VLT), T1 will start to turn off. This allows T2 to begin to turn on again, adding its own emitter current to T1's and so nudging the emitter voltage upwards. This compels T1 to turn off more quickly, and once again positive feedback snaps the circuit into its other state, with T1 off and T2 on.

Formulas: (neglecting junction voltages)

- $V_{HT} = R_e / (R_e + R_{c2}) \times V_+$
- $V_{LT} = R_e / (R_e + R_{c2}) \times V_+$

Simulating a Schmidt Trigger

The circuit of the 8012B is exactly the same as the one described in Wikipedia, except that it uses small inductors as collector loads. We will examine this in more detail, but before we get to the process of naming the culprit, we need to talk about the pulse shapers.

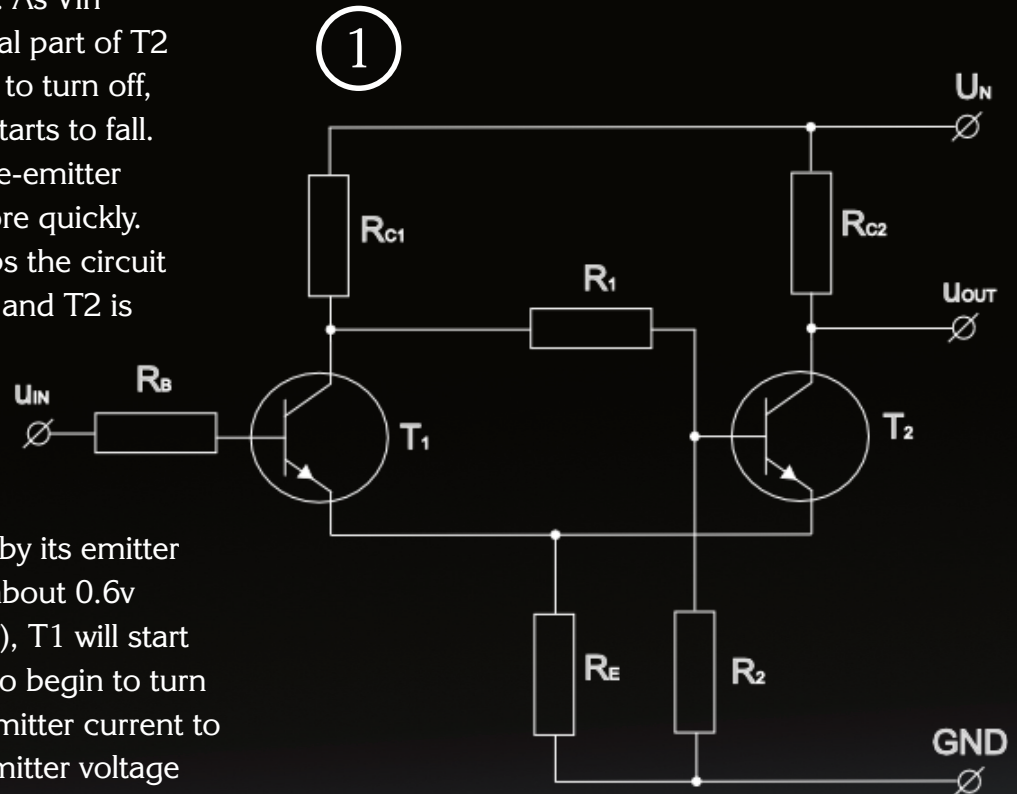

In the picture, a transistor-based Schmidt Trigger, from Wikipedia.

The schematic is by Di Audrius Meskauskas - Opera propria, CC BY-SA 3.0, <https://commons.wikimedia.org/w/index.php?curid=633382>

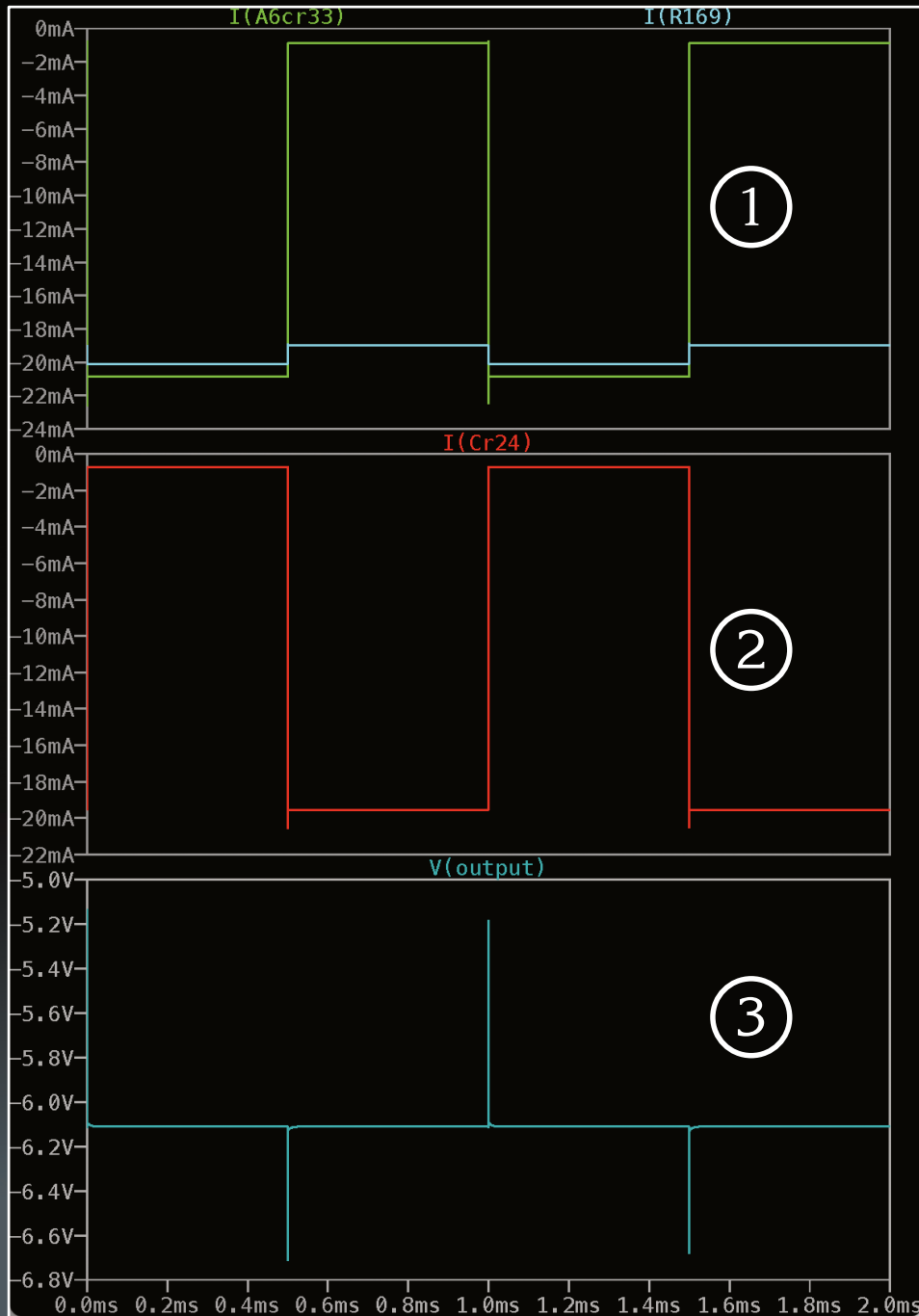

- ❶ The current in the inductor leg (in blue the total current in R169).
- ❷ The current in Q53 compensates for the current in the inductor when this is not active.
- ❸ The output pulses, formed as they should.

Not All The Mysteries Have Been Solved

I also had to increase L2 from 0.220uH to 0.470. The idea came from the manual itself, where I noticed that many inductors had been increased in subsequent product changes. But why? Surely the unit worked at some point. All the resistors kept their value, but the inductor had to be changed if I wanted a working 8012B. I have no answer to that question.

THE DARK AGES

Not Everything Was New

Though significantly different, the 8165A clearly shows the hand of the same designers who created the 8015A and 8012B.

Not Everything Was Good

For these reasons, I approached the 8165A with preconceptions, because my experience with the previous generators had not been so good, and, rightly or wrongly, they mean to me:

- low reliability;
- extremely complex circuits with many transistors interacting with each other.
- manuals with few explanations and waveforms, and no voltages at all. Also with some errors or wrong indications (...very different from Tektronix);
- often everything seems to be OK, but it doesn't work...;
- even if it works, you are not sure if it works as it should;
- etc.

In this case, my preconceptions were partially correct, and I spent weeks trying to fix this 8165A. I was not fond of the old 8000 series, so I ended up sticking with the 8165A, even though I am usually in love with most of these old electronic monuments.

With my eyes today, it seems to me that this breed is not the best in the glorious history of Hewlett-Packard; yes, digital solutions are starting to appear, but the effort to integrate them into an essentially analog design is still clearly noticeable.

Something like the **Dark Ages** of Hewlett Packard, waiting for the 3325A (etc.) **Renaissance**. But perhaps this is just my fantasy...

Block Diagram

To meet these and other requirements the design concept is as shown in the block diagram below.

A 1-kHz-to-50-MHz oscillator (HF VCO in Fig. 3) generates a triangle output that may be used directly or fed to a sine shaper. The square wave is derived from the HF VCO's current switch drive voltage. Changing from triangle to ramp form, and consequently changing the square wave duty cycle, is achieved by varying the charge and discharge rates of the HF VCO's ramp capacitor. Duty cycles and ramp symmetries of 20%, 50%, and 80% are available. For high stability in continuous operation, the HF VCO can be phase-locked to an internal or external 10-MHz frequency reference.

Signals below 1 kHz are generated by a low-frequency generator (LFG). Simplified, it consists of an up-down counter (to divide the frequency) followed by a digital-to-analog converter (to synthesize a triangle). The counter is clocked by the HF VCO at a frequency 10,000 times higher than the output frequency of the D/A converter. This allows the HF VCO to run continuously in the phase-lock mode even when a triggered low-frequency signal is required. Consequently, the basic crystal accuracy and stability of the output are preserved in all operating modes, and also phase noise should be lower in this way.

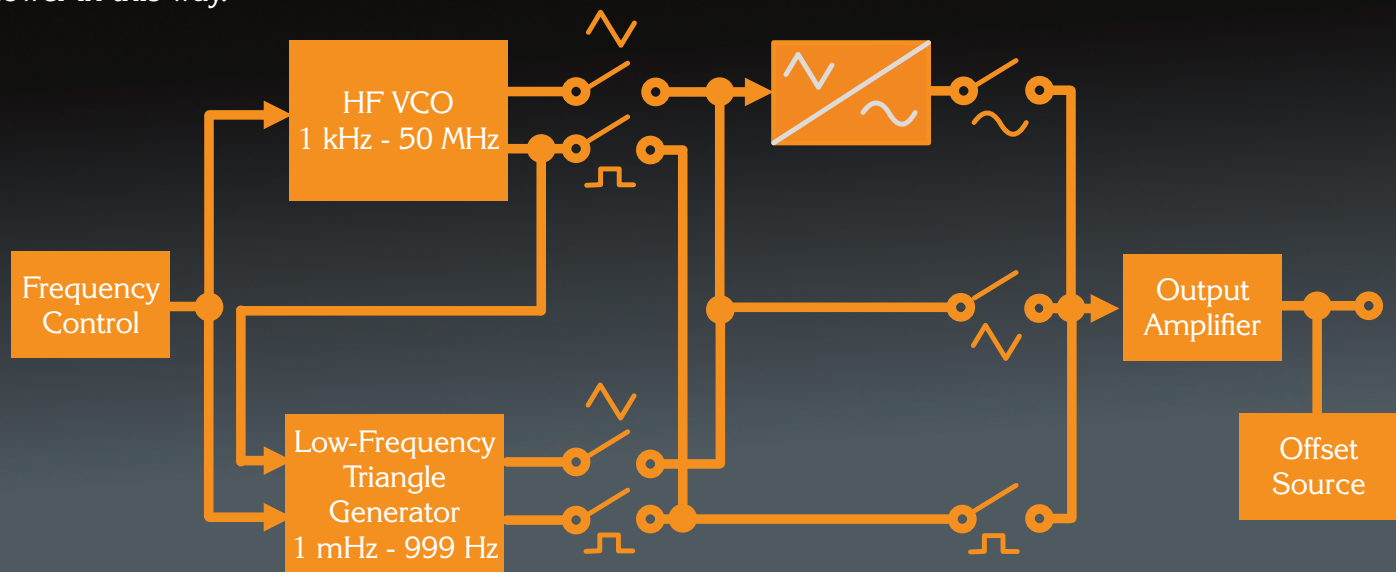

8165A general schematic (redrawn from HP Journal). It is almost two instruments in one: one for high frequency (1 kHz to 50 MHz) and one below 1 kHz. The latter is all-digital and therefore much more accurate and precise, including waveform quality.

A5 Board: VCO and Sine Shaping

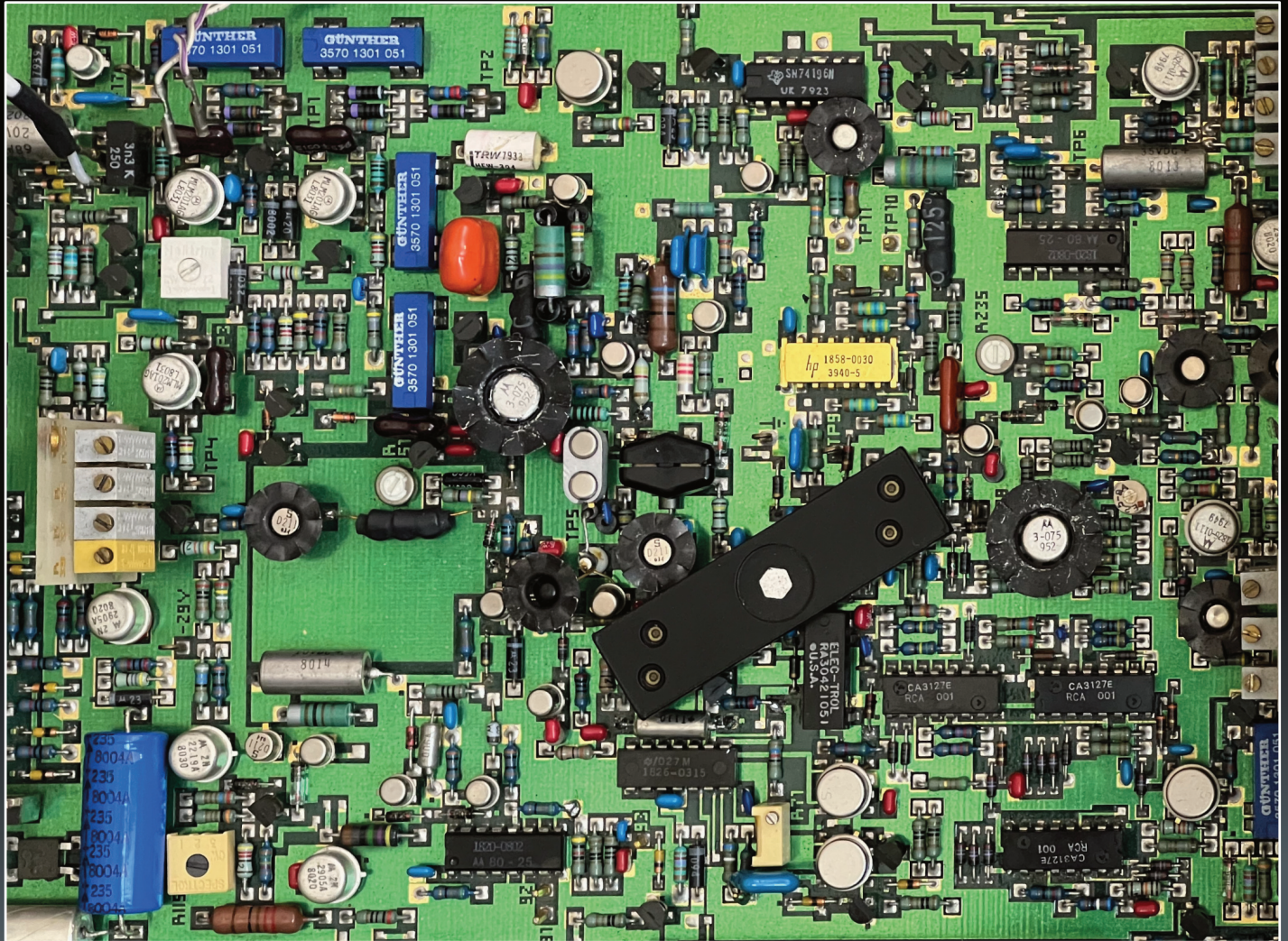

The VCO is entirely contained in the A5 board, together with the sine generation and other circuits. The A5 board is the motherboard, where most of the other boards are inserted. Here in this photo you can see only the effective area of the A5 circuitry.

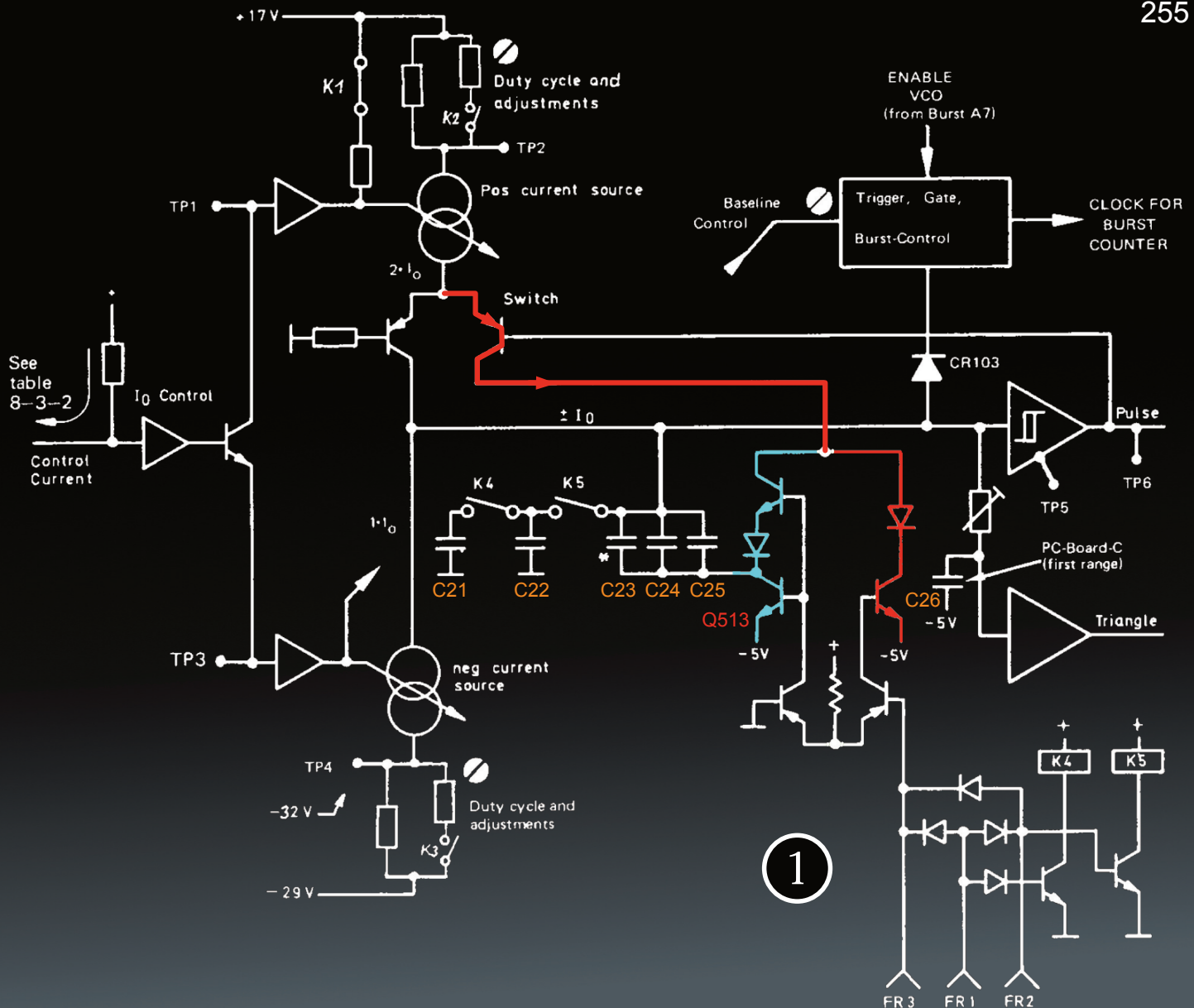

① In red, the circuit that allows to set correctly the reference ground for capacitors switched by transistor instead of a relay, to compensate for transistor V_{be} . Red path is used in other cases.

② The high frequency compensation circuit described in the text is adjusted during calibration @50 MHz.

FRQ range	FR1	FR2	FR3	K4	K5
1 kHz – 9,999 K	1	0	0	ON	ON
10 kHz – 99,99 K	0	1	0	OFF	ON
100 kHz – 999,9 K	0	0	1	OFF	OFF
1 MHz – 50 MHz	0	0	0	OFF	OFF

Direct VCO Control

You can control the VCO directly from an external DC source connected to the front panel BNC input by pressing the VCO button. The manual says 10 mV to 10 V for a 3-decade sweep (but you have to set a frequency value to select the range).

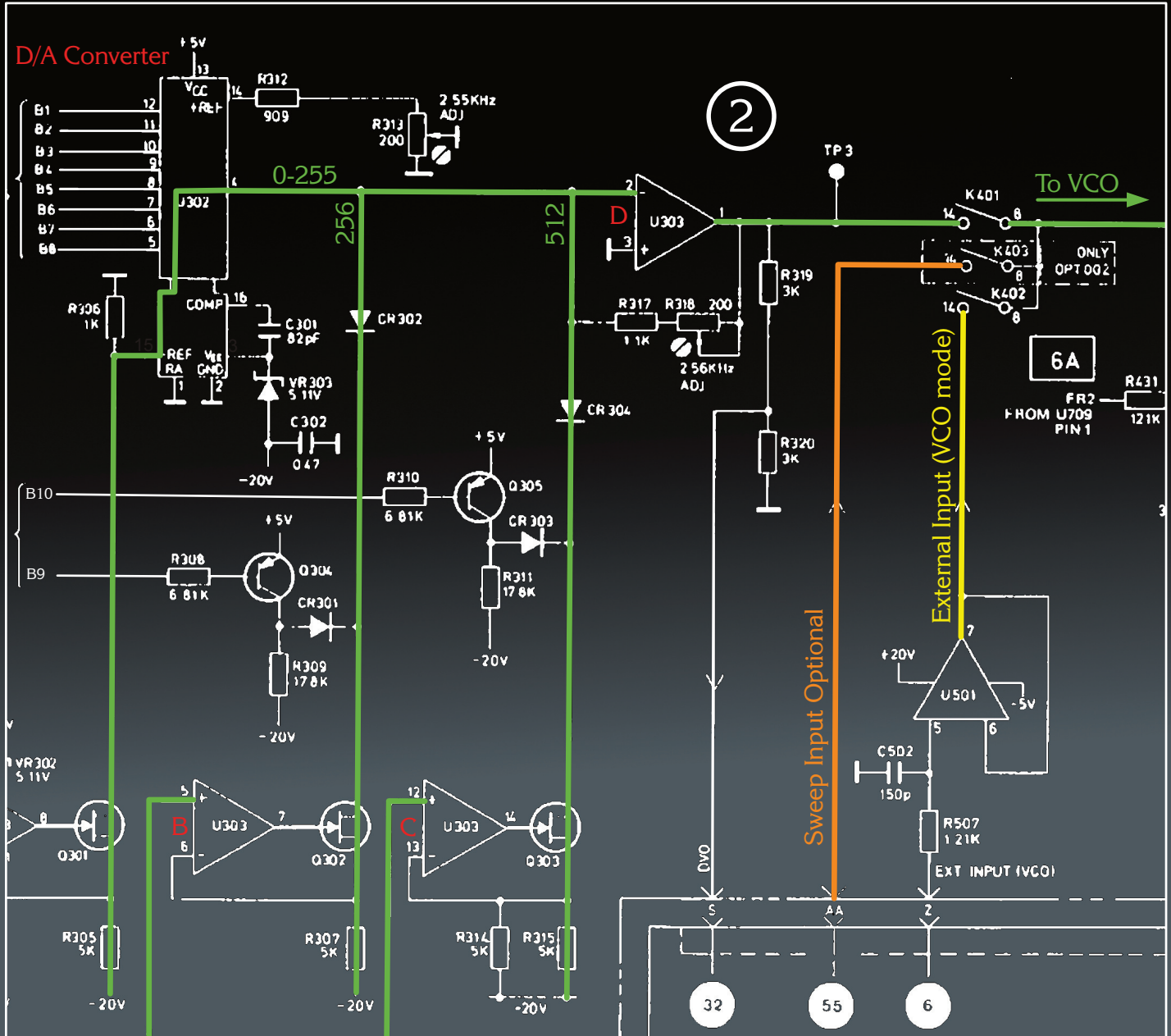

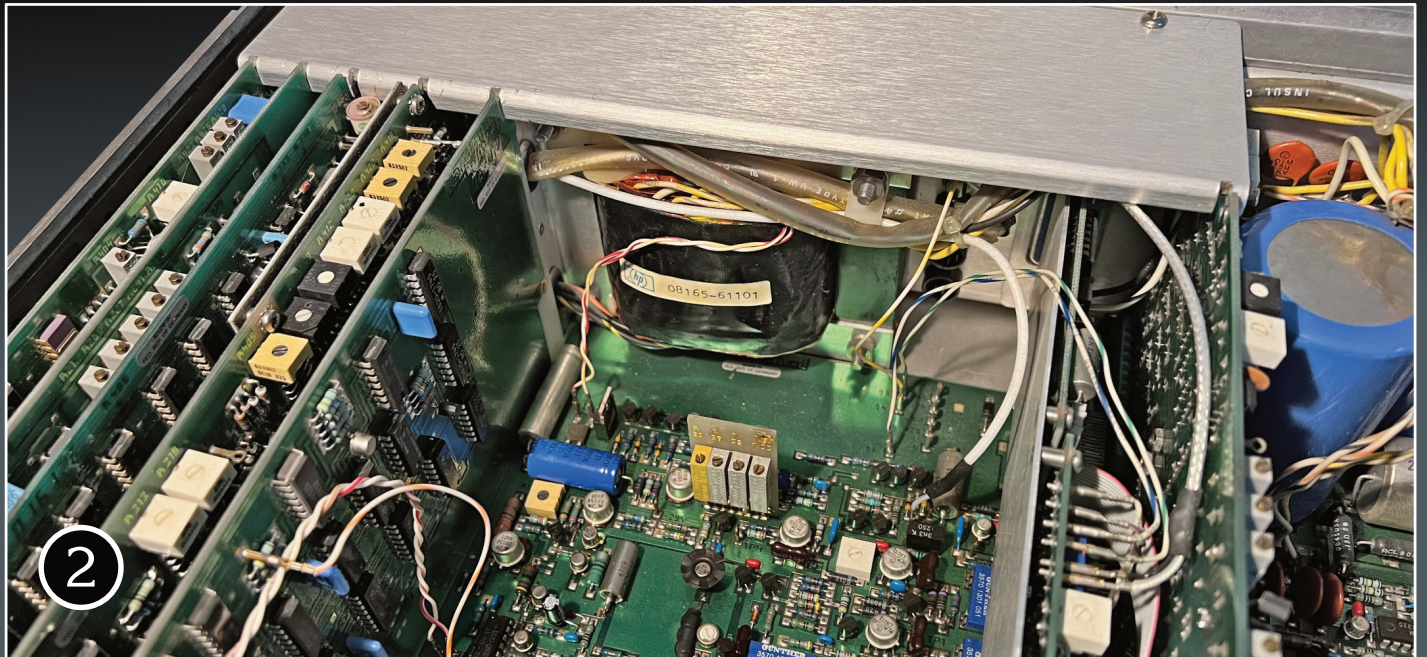
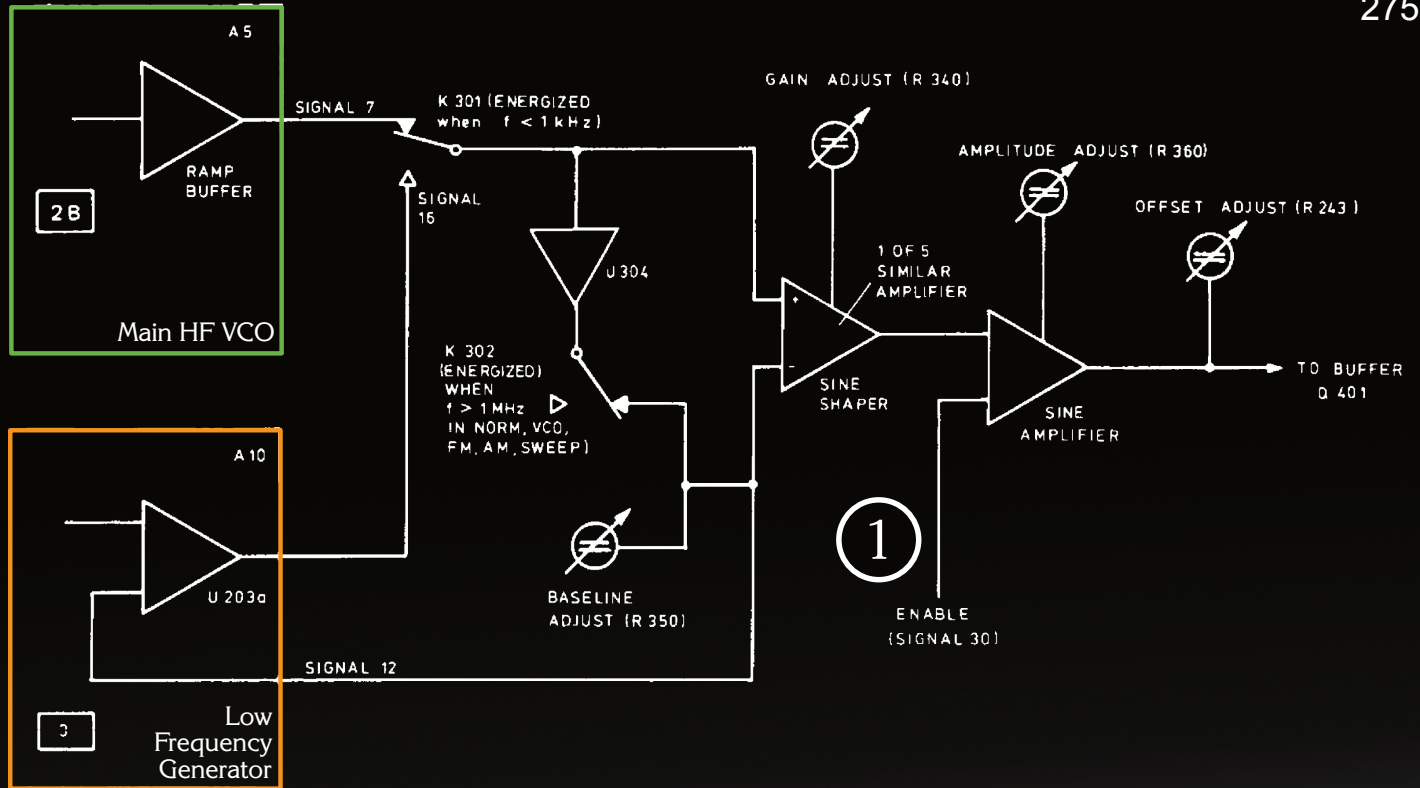

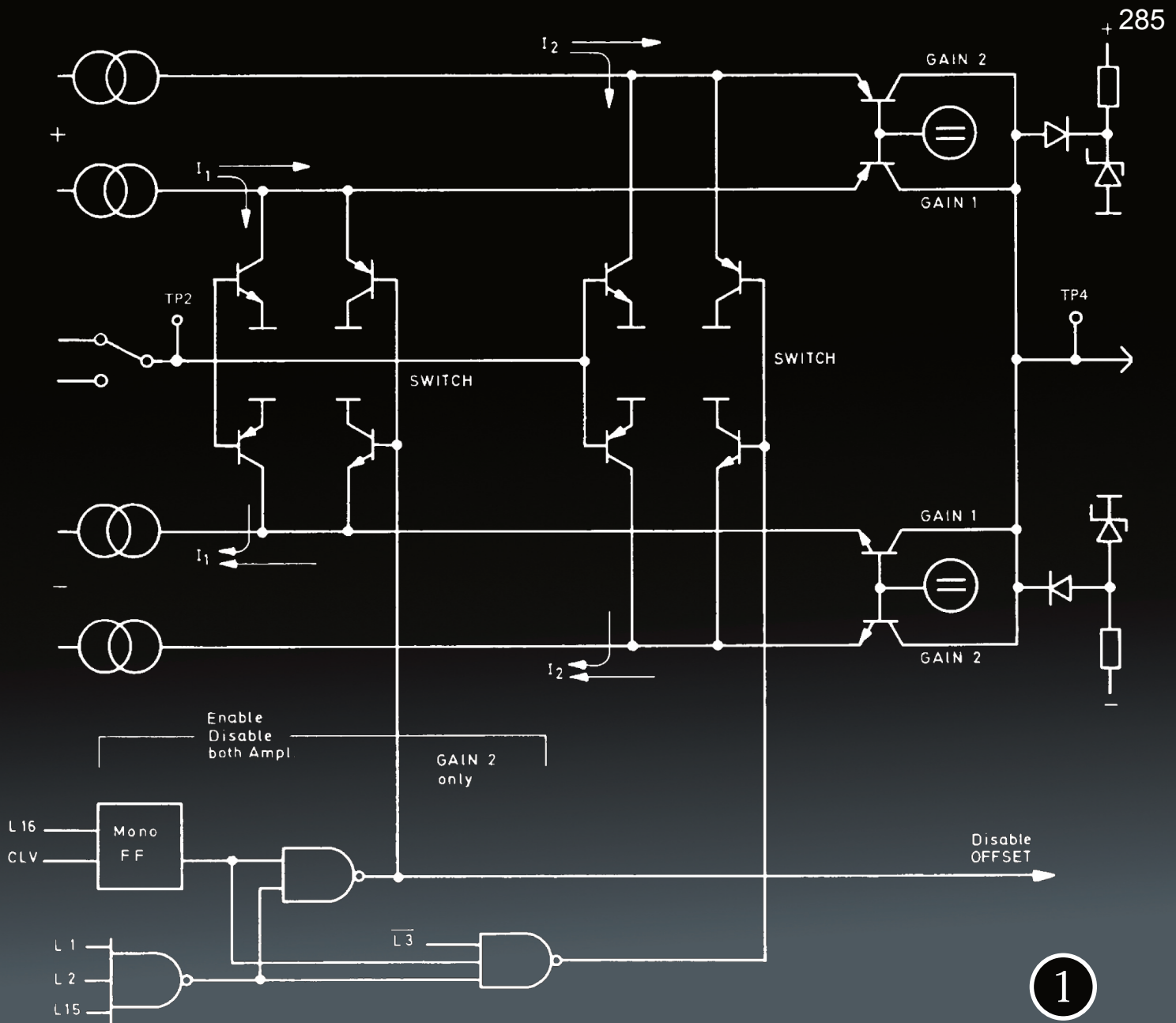

The positive cascode stage comprises common emitter transistor 0301, common base transistor Q303 and the positive current source; the negative cascode stage comprises common emitter transistor Q304, common base transistor 0306 and negative current source. 0301 and Q304 operate as voltage-controlled current sources, the input voltage to their bases determining which is more heavily

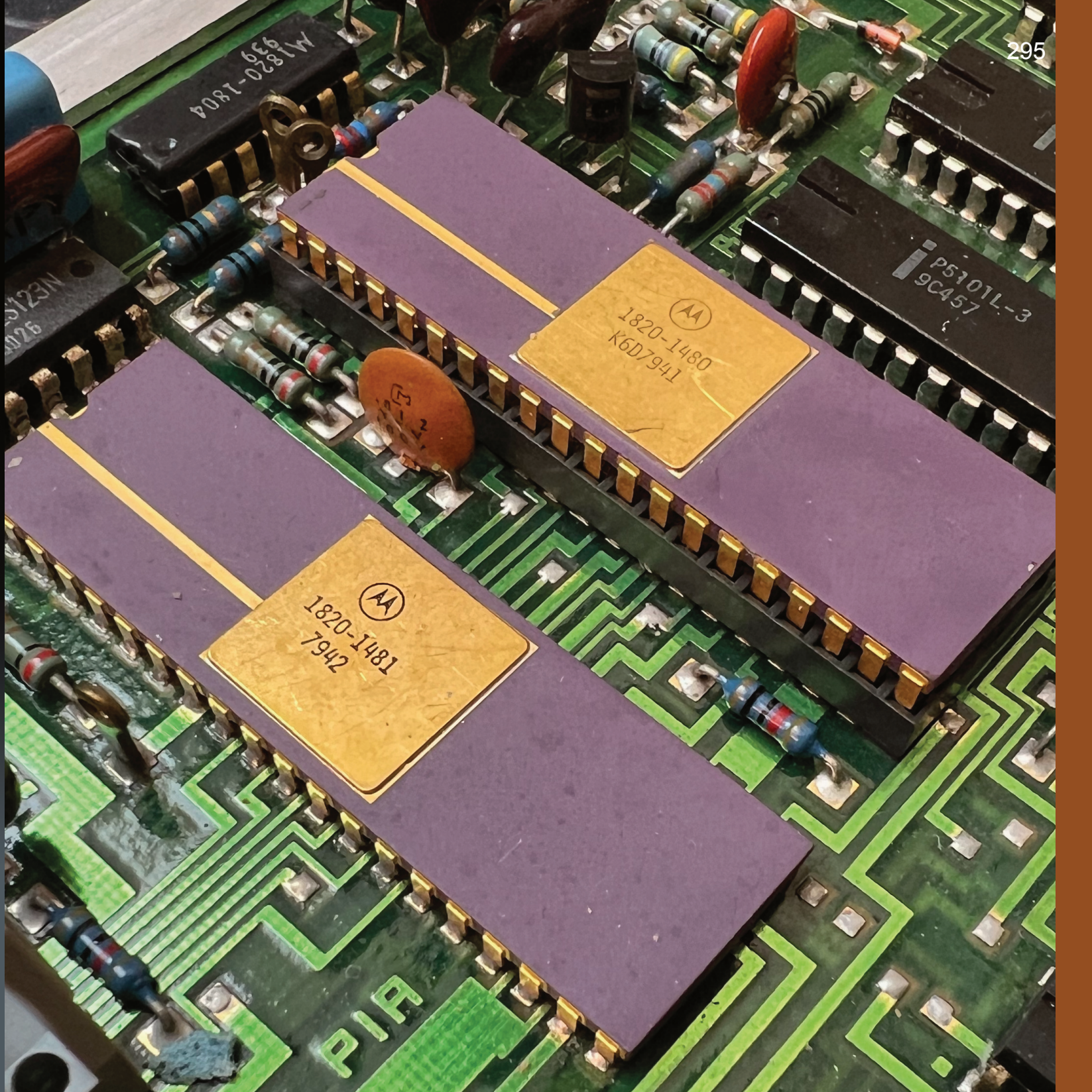

M1820-1804
939-1804

Ⓐ
1820-1480
K6D7941

P5101L-3
9C457

Ⓐ
1820-1481
7942

123N
26

5
2

PIE

Even in VCO mode, when the output signal should only be controlled by a DC voltage, it only worked in the upper part of each range. No lucky condition, such as disconnected connectors, gave any hope, and trying to understand the inner workings was the only possible way. Youtube does not help: it seems that nobody had this problem.

The Approach

I am not sure if mine was the best approach, but the only way I know in cases like this is to study and document. These pages are just a summary of all the notes I collected and wrote down. That is why I have documented so much about the ramp generator and its trigger. Anyway, even though I think I understand most of the details of this area, I wouldn't have gotten anywhere without a little luck.

The Magic 100 Ohm

An important turning point was when I noticed that things got better when the trimmer R71 (picture on the right) was screwed in for the minimum resistance. So the current in the trigger is not enough, I thought, and decided to add a 100 Ohm resistor in parallel to R70. This had a magical effect and even locked the PLL on some occasions. In parallel, the horrible output signal started to look more acceptable. After that I doubled the energies and studied the trigger, but .. with very little results.

A Digression

At this point I decided to take a digression and study the PLL. I was glad to see that Loop1 and Loop2 were working properly, and that the PLL sometimes worked quite well. I also discovered that many things worked fine until I enabled the PLL (NORMAL button). But I also discovered that I had forgotten to remount Q203, the only one that could really enable/disable the PLL operation. It seemed impossible, but the NORMAL button has no other effect.

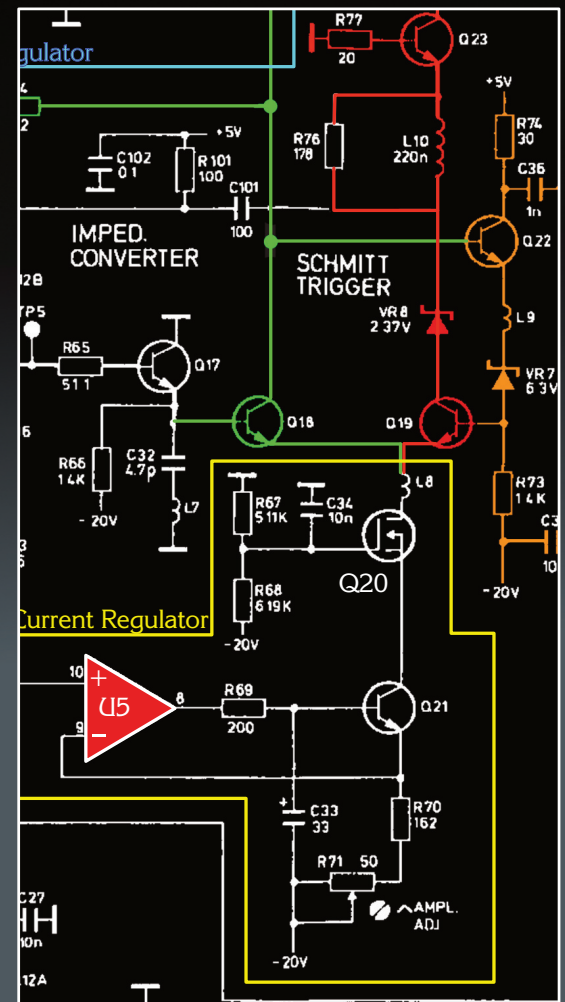

Section:

Signal Sources

Subsection:

3325A Function Generator

An absolute top-class pulse generator, probably much more than it could be required by the average electronic laboratory.

Option 002 High Voltage Output

Frequency Range

- Sine and Square Wave: 1 μ Hz to 1 MHz;
- Triangle and Ramps: 1 μ Hz to 10 kHz

Amplitude

- Range: 4 mVp-p to 40 Vp-p ($\geq 500\Omega$, $< 500F$ load) maximum output current, ± 40 mA
- Accuracy (at 2 kHz): $\pm 2\%$ of full output for each range
- Flatness: $\leq 10\%$ of programmed amplitude

DC Offset

- Range: 4 times the range of the standard instrument
- Accuracy: $\pm(1\% + 25 \text{ mV})$ of full output for each range

❶ A8 Board, Option 002.

❷ A9 Board, Option 001; the This photo comes from <https://bukosek.si/hardware/collection/hp-3325a.html>

❸ The transformer has dedicated wires for the Option 002. Probably, they are always present even without the option, to allow however to install it at a later time.

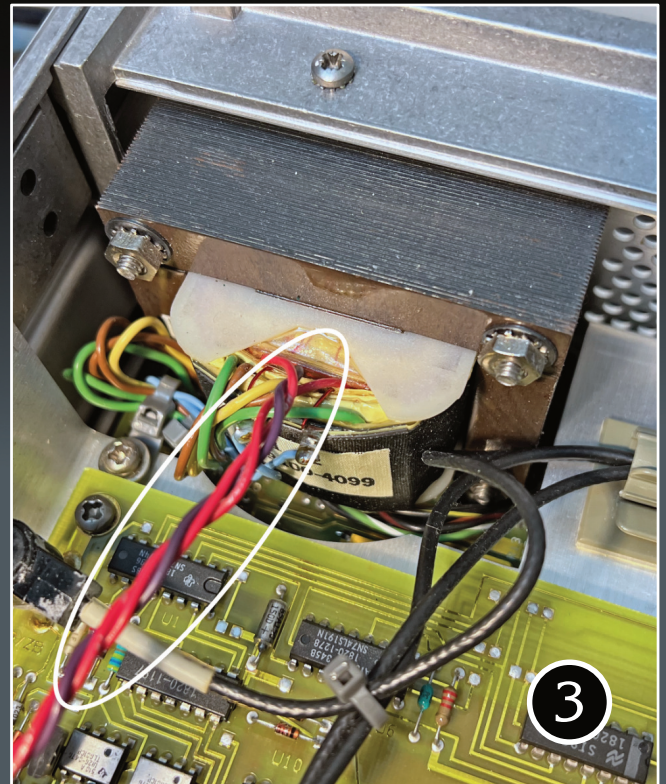

it runs at 40.2 MHz, and so on. In this way, changing the value of $\div N$ changes the generated frequency in discrete steps.

A PLL that operates only by changing the divider ratio in whole-number steps is called an Integer-N PLL.

3325A Output Signal

In the 3325A, the VCO signal is not used directly as the instrument output. Instead, it is mixed with the 30 MHz signal derived from the reference oscillator.

Therefore, if the VCO is operating at 40 MHz, the resulting output is 10 MHz, i.e., $40 \text{ MHz} - 30 \text{ MHz}$.

For example, if $\div N = 398$, the VCO is set to 39.8 MHz ($398 \times 100 \text{ kHz}$), and the resulting output is 9.8 MHz.

The value of $\div N$ is established by the control circuitry in response to front-panel settings or remote programming. In normal operation, the 3325A takes about 50 milliseconds to complete a frequency change.

Practical Note: the 3325A VCO control voltage comes from the connector A21J18A (cable marked 81 S-H). A +10 V input produces 30 MHz frequency; +5V=42.6 MHz; -3 V=60.9 MHz.

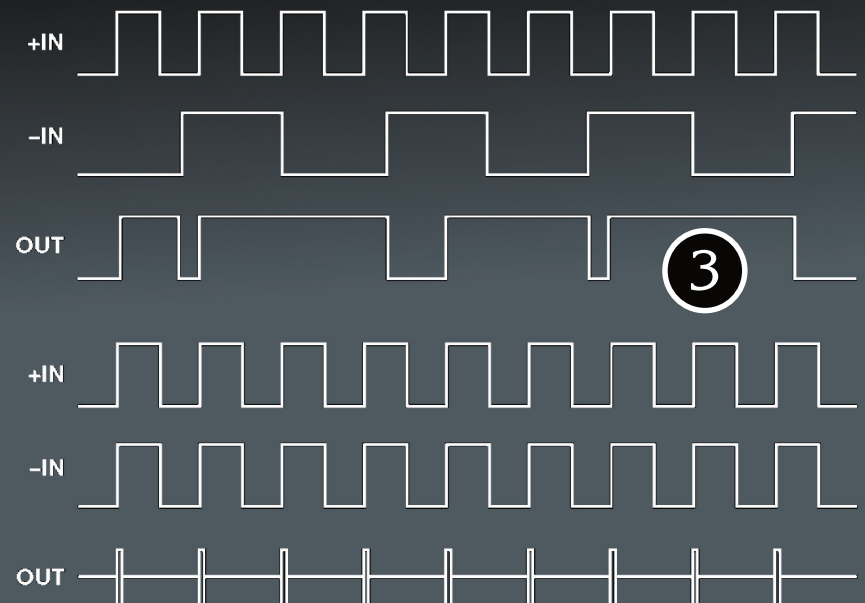
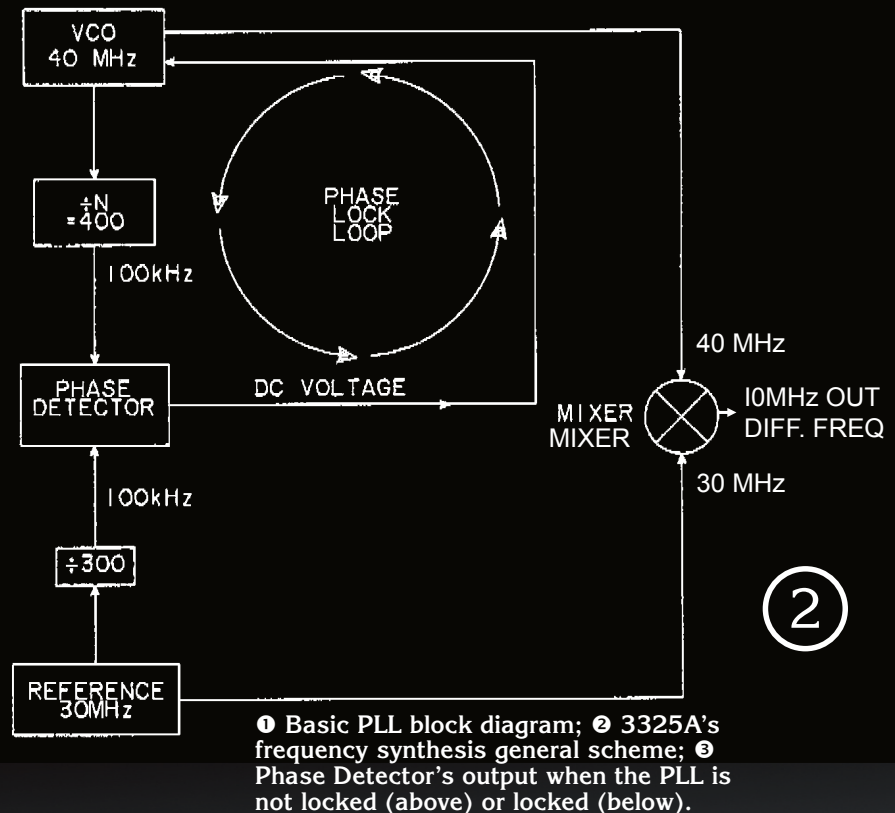

The table below makes this much easier to visualize. In **Example 1**, the required divide ratio is 345 400, corresponding to a VCO frequency of 40.000 MHz and an output frequency of 10.000 MHz. The 9's complement of 400 is 599, so the counter is preloaded with 599 and then counts up to 999. Since this requires exactly 400 input pulses, one output pulse is produced for every 400 VCO cycles, and the VCO signal is therefore divided by 400.

In **Example 2**, the required divide ratio is 301, corresponding to a VCO frequency of 30.100 MHz and an output frequency of 100.0 kHz. In this case, the 9's complement of 301 is 698. Again, the counter counts from the preset value up to 999, and since that span contains 301 counts, the effective division ratio is 301. The table therefore shows clearly how the complement-to-999 method allows the divider to realize the required value of N without counting from zero.

A complication appears when N is odd, as in Example 2. Under normal conditions, the least significant digit section would count only an even number of cycles, because the divide-by-5 counter is driven from the prescaler operating at $VCO \div 2$. To make an odd divide ratio possible, the prescaler is temporarily forced to divide by 3 for one cycle instead of by 2. This inserts the extra count needed to realize an odd value such as 301.

	Example 1	Example 2
Sine wave output	10 000 000.0 Hz	100 000.0 Hz
Reference frequency	30 000 000.0 Hz	30 000 000.0 Hz
VCO frequency	40 000 000.0 Hz	30 100 000.0 Hz
$\div N$	400	301
999-N	599	698
9's complement of N	599	698

In the 3325A, this correction is enabled when the least significant BCD bit of the preset least significant digit indicates that an odd count is required, as in Example 2, where the preset digit is decimal 8 (binary 1000). A negative-going pulse from the preload one-shot then switches the prescaler to divide by 3 for one cycle. This odd-count correction is separate from, and additional to, the pulse-removal action associated with fractional-N operation itself.

The divider output pulse is derived from the bias pulse produced by the fractional-N control IC and is then synchronized to the VCO timing. The prescaler output, further divided by five, also provides the internal chip clock used for the timing and synchronization functions of the fractional-N control circuitry. A cycle-start pulse occurs each time the least significant digit is preloaded, that is, once every reference period, and this pulse initiates the internal control sequence.

Sweeping

Frequency Sweep

An important addition to a function generator is the ability to automatically vary the frequency of the signal over a specified range at a constant amplitude, a feature usually called a sweep. This is normally used to determine the behavior of a component or circuit, such as the frequency response of an amplifier, or to help tune the IF stage of a radio receiver. I also needed something like this when I was designing contactless antennas for smart card readers, and I used a spectrum analyzer with a tracking generator to do it.

3325A Features

The 3325A has the sweep possibility, with some improvements over the old generators:

- a **wideband** sweep;
- there are **no phase discontinuities**, usually associated with synthesizers. Sweep is phase continuous over the full frequency;
- range of the main output.

The user has control of the **start** and **stop** frequencies, choice of **linear** or **logarithmic** sweep, and **sweep time**. The linear sweep has single-sweep and continuous-sweep modes with sweep times between 0.01 and 100 seconds. Total sweep times for single log sweep range from 2 to 100 seconds or 0.1 to 100 seconds for continuous log sweep. **X-axis** and **Z-blank** outputs are provided for driving CRTs and X-Y recorders. Also available is a TTL-level **MARKER** output that changes state during a linear sweep when the output frequency passes through the selected marker frequency.

Logarithmic sweep is approximated by a succession of linear segments. A new frequency increment is loaded 10 times per decade during single sweep. Convenient "zoom" functions AFx2 and AF÷2 to quickly change the frequency span are supplied.

How Does It Do?

Phase-continuous frequency sweep of all functions was made possible by the addition of another register and BCD adder-subtractor to the count-by-O.F section.

A frequency increment stored in this register is added to the F register during each reference period to cause the frequency to sweep up. Sweep down is accomplished by subtracting the increment.

- when the SIGNAL button is pressed (key indicator on), the front panel SIGNAL connector can provide a maximum output of 40 V p-p into a 500-ohm load. The maximum frequency for sine and square wave functions is reduced to 1 MHz, while triangle and ramp functions remain at 10 kHz.

Refer to the Operations and Service Manual, Section VIII, Service Group M, for instructions on activating the rear panel signal output in one of two ways:

- place the standard/high voltage output on the rear panel only, disconnecting the front panel signal output;
- disabling the high voltage output and enabling the standard front/rear output configuration.

Sync Connector

It is located on the front panel and outputs a front at the signal zero crossings.

Other Rear Panel Connectors

Other connectors are provided on the rear panel (figure on page 366).

- ❶ **MARKER TTL** – high to low TTL compatible voltage transition at selected marker frequency, sweep up only;
- ❷ **X-DRIVE 0-10V** – 0 to +10 V DC linear ramp proportional to sweep frequency (sweep up only);
- ❸ **Z BLANK TTL** – low at start of sweep, high at stop. Remains high until start of next sweep;
- ❹ **AUX 0dBm 21-60 MHz** – see text;
- ❺ **SYNC OUT** – same as SYNC on the front panel. It outputs a front at the signal zero crossings;
- ❻ **EXT REF IN 1,10 MHz >0 dBm** – external Reference signal, automatic detection;
- ❼ **REF OUT 1 MHz 0 dBm** – reference signal output;
- ❽ **SIGNAL** – see text;
- ❾ **PHASE MOD ±5V** – phase modulation input;
- ❿ **AMPLITUDE MOD ±5V** – amplitude modulation input.

Connectors' Waveforms

To better explain the signals on the various connectors, a collection of waveforms is reported on the next page.

The A3 board with the U15 chip replaced by a socket (circled in red), ready to accept the new 3127E on the way to arrive.



Surprise!

You Are Mad

You told us that:

- you passed on the 8160A in favor of the 8165A because you didn't like it;
- you said that the 8160A is just an 8015A in disguise, which you hate;
- you said you hated working on those 1000 transistor circuits;

and now you come up with the 8160A?

Well, folks, the point is that part of my hatred for these devices is due to the fact that I don't understand their circuitry, and like any human being, I tend to loathe what I don't understand...

But working on the 8165A has partly changed that, because it has forced me to study and understand. It's not love yet, but...

In addition, the devil did his work and offered me an 8160A for 87 Euros plus 15 for shipping. Hard to resist... Of course it is not in perfect condition, so I expect new days of battles. But it arrived today and I can't wait to get my hands on it.

8160A Pulse Generator



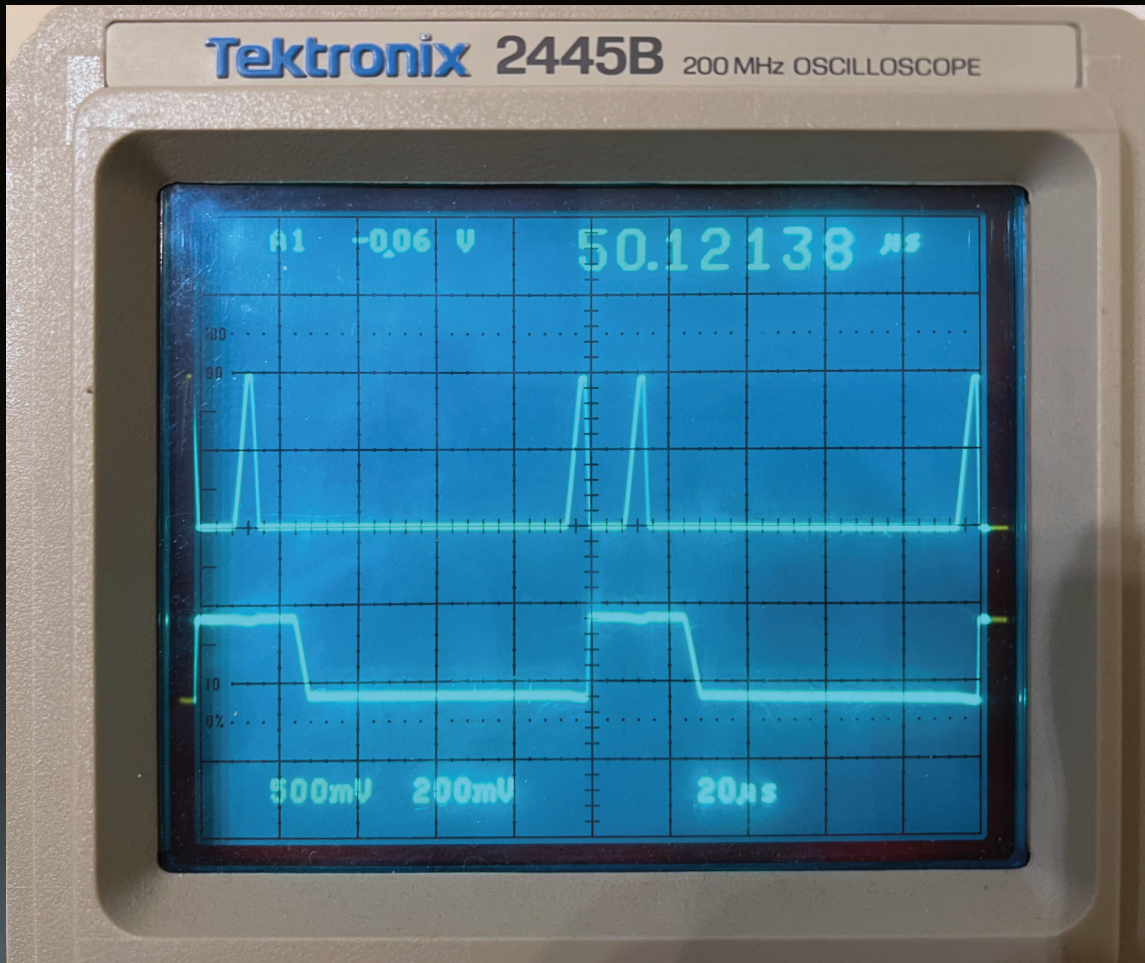
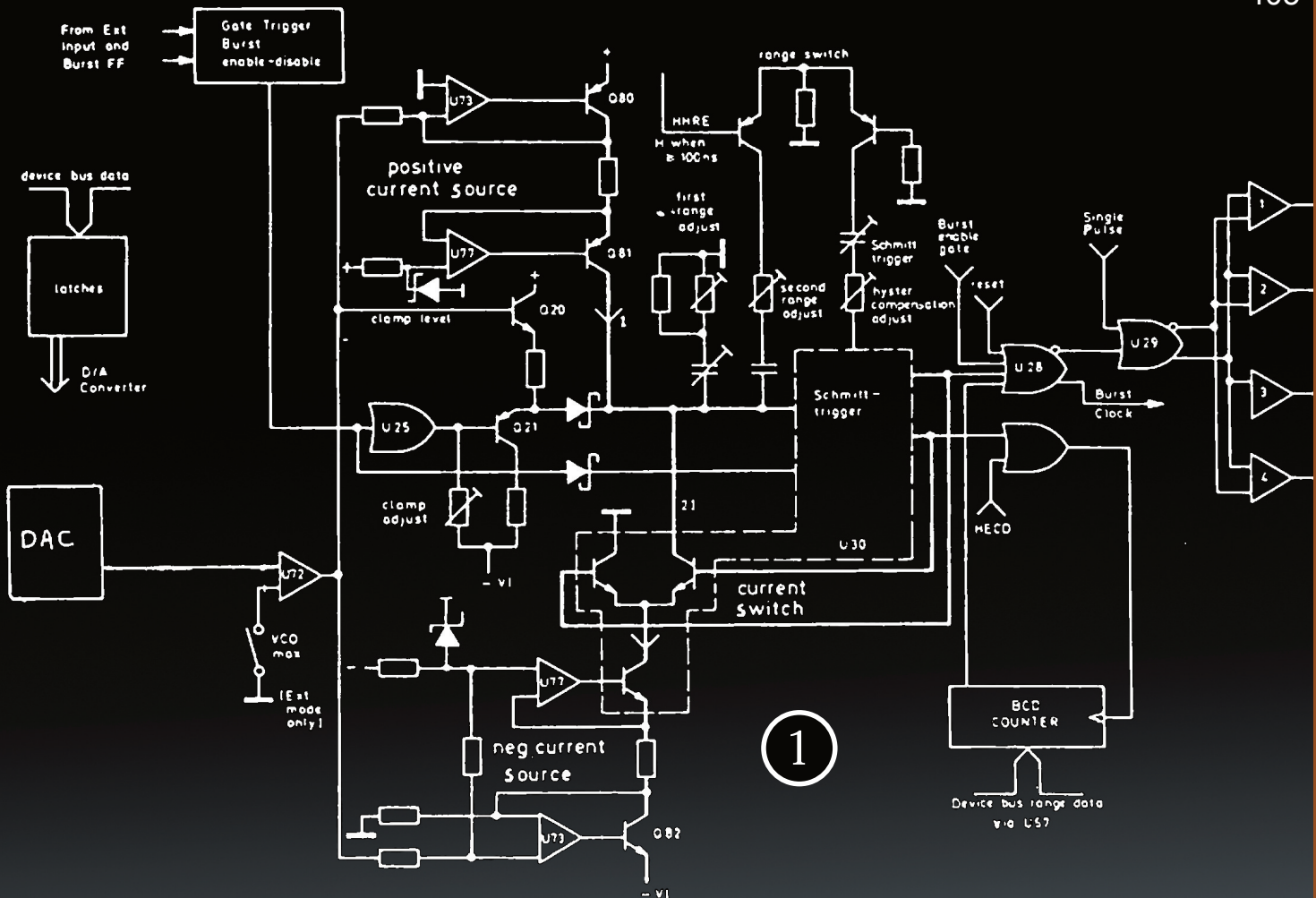

Photo: the 8160A allows you to define the pulses produced with extreme "precision", using the term in its broadest and most intuitive sense. To appreciate how flexible and "precise" it is, you need a good oscilloscope.



❶ A more detailed block diagram of the VCO. ❷ My frequency stability test @100us period. As you can see, after half a hour, the stability is more than excellent: about 1 Hz, a true record for a free oscillator.

The change in hysteresis is compensated for by sensing the chip temperature and altering the temperature-compensation current accordingly. The resistor in series with the ramp capacitor for the 20-99-ns range has a negative-temperature-coefficient to compensate for temperature-induced changes in propagation delay.

Don't Question Me, Please

I tried to understand all this circuitry, but it was not easy. After studying the HP Journal and the manual, don't ask me about it anyway...

The Boards

Position-free?

The top cover of the housing shows board arrangements for both the standard model and that with option 020. For what I could understand, boards can be placed in almost any position, but Time Interval blocks must not be separated and cannot be placed across the established position, because use some lines to interconnect each other. For example, board addressing is performed by board A128 and then passed to latches A126' and A127'.

I named the Time Interval boards as A126, A127 and A128, meaning with them the model type, but when inserted on the bus their ID changes adding "100" for each group, so e.g. channel B width Time Interval block is numbered A426, A427 and A428.

Why Should I Do This?

You could think that this is just a lucubration of mine; just set the boards where they belong and don't bother us... On the contrary, it can be useful to remove the central boards and put the boards under test on the right, to have room to access them with the scope probe. With some smart adjustments, you can survive in some way even without dedicated board extenders.

- ❶ The cover internal showing board arrangements for both base model or Option 020
- ❷ Time Interval blocks in my 8160A; each of them is composed by three boards. Each block is identical to the others and distinguishes only by switches settings, so that in theory yours could have a different arrangement.

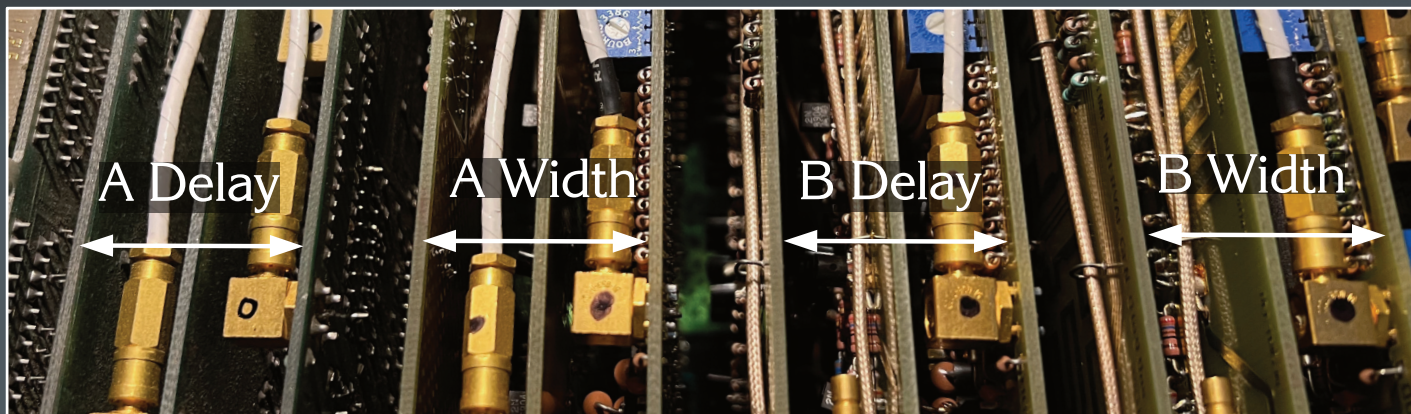

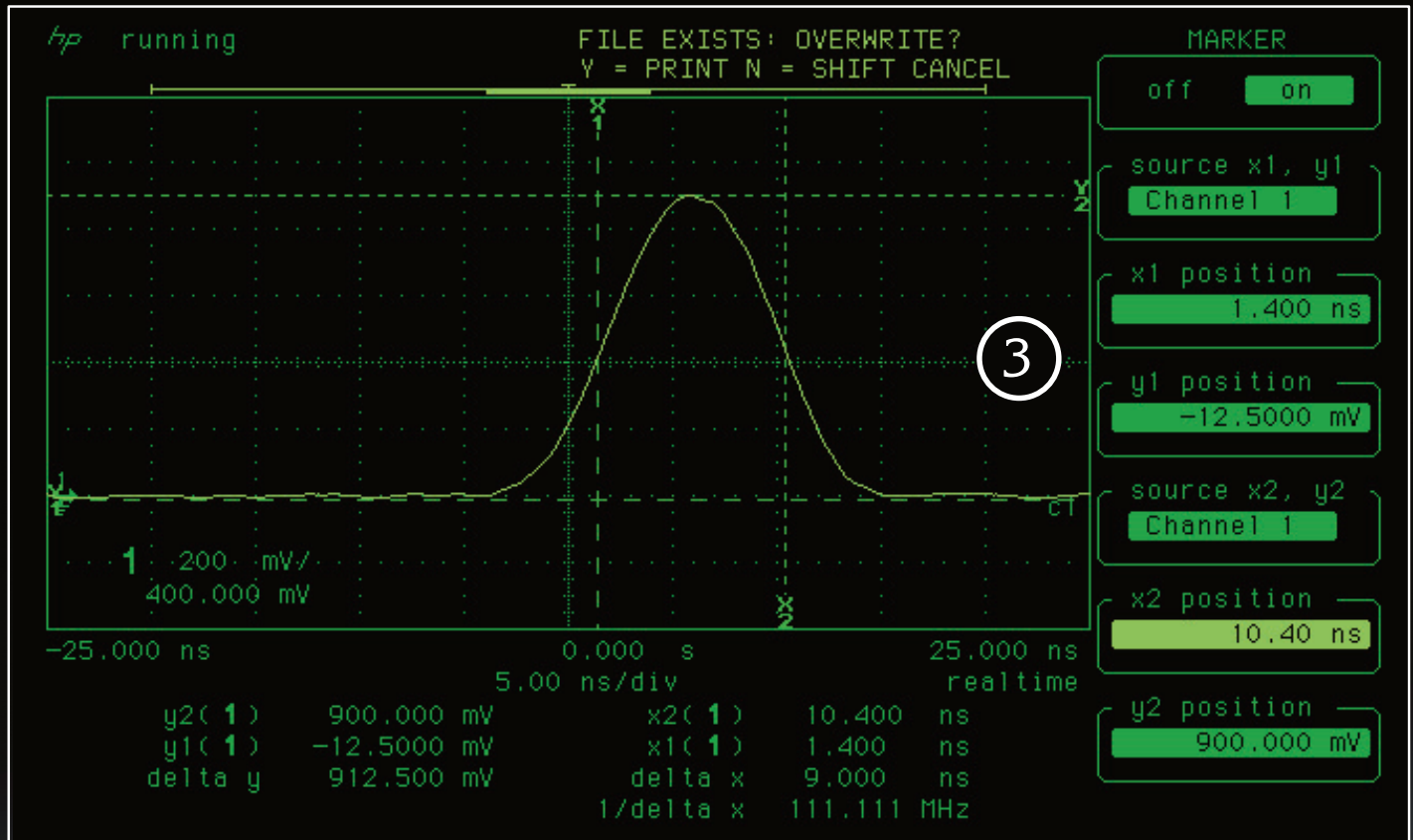

Some Shots

The 8160 was set for 100 us repetition rate, minimum pulse 8 ns with 3 ns leading and trailing edges.

- ❶ Wonderful performance of **Tektronix 7834**, one of my most beloved, in reduced scan mode, @ 2 ns/div in single shot thanks to 7B92A time base and 7A19 vertical amplifier, externally triggered by the 8160A. It could do even better, but the delay line moved the pulse to the right, outside of the screen.
- ❷ The same pulse on **Tektronix 2440**; 500 MSa/s; note the almost correct automatic measurements . Obviously, much easier to use than the 7934.
- ❸ The same pulse on **HP 54540A** 1 GSa/s. Top performer, it can also record the screen on floppy, to reduce my editing effort...
- ❹ and ❺ a touch of vintage: **Tektronix 545B** and **545**.

I thought that the half-broken driver had definitely failed and was no longer working at all. It was 445 easier to start by removing acceptors to eliminate them from the suspect list, and so I removed all the boards that compose option 020 (BTW, I believe option 020 was so expensive when I saw all together the 9 boards that compose it!). But with the 9 boards removed, nothing changed and I decided to a) analyze the problem better and b) analyze the peripheral bus with a scope.

The Solution

At that point I had a good inspiration, and decided to extract/insert the A2 microprocessor board more times. This solved the problem. To be more sure of the result, I replaced the two missing screws which lock the A2 board in place (photo ❶). I lost other time reinstalling the boards, but now the problem was really over.

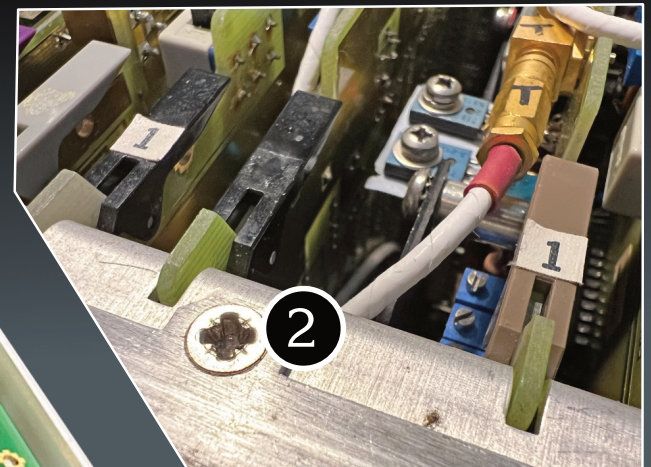
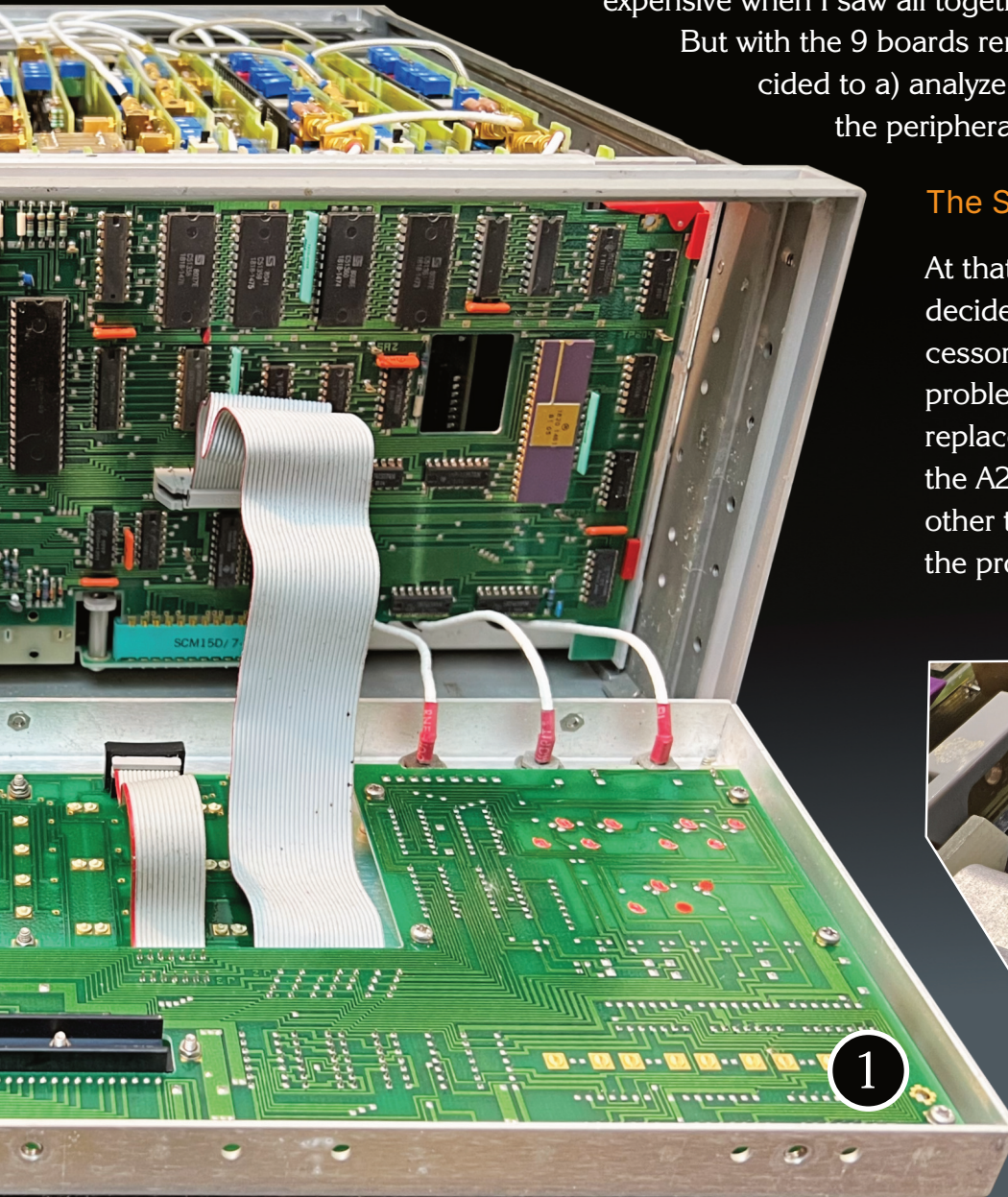

front panel. Good HP engineering... In the circle the original location of the RAM batteries. I suggest to move them to a safer location to protect the board against possible acid leaks. ❷ One of the two screws which keep in place the A2 Microprocessor Board.

❶ The 8160A's A2 microprocessor board can be easily serviced just tilting down the

Phase Noise @ 20 MHz

